

HURLSTONE AGRICULTURAL HIGH SCHOOL

2003

HALF-YEARLY EXAMINATION

General Mathematics

Examiners: R. Yen, P. Marsh, S. Gee

GENERAL INSTRUCTIONS

- Reading Time – 5 minutes.
- Working Time – 2 hours.
- Write using blue or black pen.
- Write the answers to each question on a new sheet of paper.
- Questions in Section 2 are of equal value.
- A formulae sheet is provided at the back of this paper.
- Board approved calculators may be used.

Name: _____.

Class: _____.

Total marks – 80

Section 1 15 marks

- 15 multiple-choice questions
- Attempt Questions 1-15
- Allow about 20 minutes for this section.

Section 2 65 marks

- 5 free-response questions (13 marks each)
- Attempt Questions 16–20
- Allow about 100 minutes for this section

QUESTION 16. Write your answers on a new sheet of paper.

Marks

- (a) A principal of \$5000 earned \$625 in simple interest after 2 years. What was the interest rate p.a. for this investment? **2**
- (b) A coin is tossed three times. Use a tree diagram to calculate the probability of tossing exactly one tail over the three throws. **2**
- (c) This dot plot illustrates the body temperatures (in degrees Celsius) of patients at a hospital. **2**

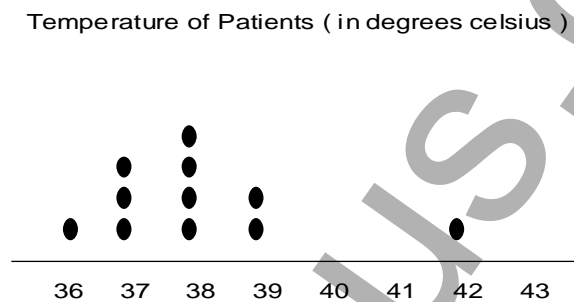

Calculate the mean temperature correct to 2 decimal places.

- (d) What principal needs to be invested at 8.1% p.a. compounded annually to accumulate to \$45 000 after 10 years? **2**
- (e) Two cars leave the same town on separate straight roads: one in a direction due east and the other on a bearing of 165° . After travelling 8 kilometres, the first car is due north of the second car.
- (i) Use a ruler and protractor to draw a scale diagram of this situation, using a scale of 1 cm : 2 km. **2**
- (ii) Use the diagram to find the distance the second car travelled, correct to one decimal place. **2**
- (iii) Use trigonometry to calculate the distance the second car travelled, correct to one decimal place. **1**

- (a) The graphs below show the annual water consumption (in Megalitres) for pensioner and non-pensioner households in Bingo Hill.

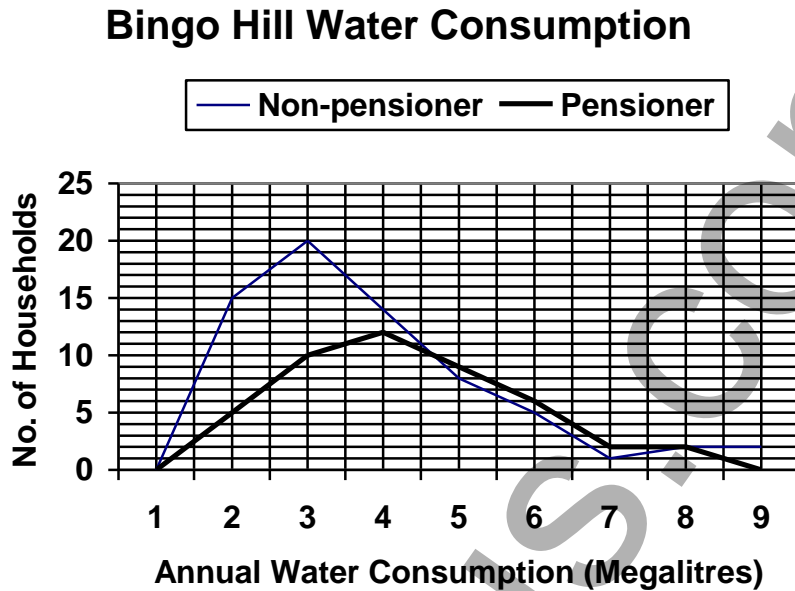

- (i) How many non-pensioner households have a consumption of 4 000 000 L per year? 1
- (ii) What is the modal annual water consumption for the non-pensioner group? 1
- (iii) The two graphs cross at where the annual water consumption is 8 ML. Explain what this indicates. 1

Question 17 continues next page.

QUESTION 17 (continued).

Marks

- (c) The 57 marks below, presented from lowest to highest, were scored by university students in a final examination.

39, 43, 45, 45, 47, 47, 48, 49, 51, 52, 53, 54, 54, 56, 56, 56, 56, 57, 57, 58, 58, 60, 60, 61, 63, 64, 65, 65, 65, 66, 67, 67, 67, 67, 67, 68, 68, 69, 69, 70, 71, 73, 74, 74, 74, 76, 77, 78, 79, 80, 82, 83, 83, 88, 88, 89, 91.

- (i) What was the median score? **1**
- (ii) What was the mode score? **1**
- (iii) Copy and complete the last 3 columns of this table. **4**

Class	Class Centre (x)	Frequency (f)	Cumulative frequency
30-39			
40-49			
50-59			
60-69			
70-79			
80-89			
90-99			

- (iv) Construct a cumulative frequency histogram and polygon from the table using the graph paper supplied on page 13. **2**
(Tear off page 13 and include it with your answers for Question 17)
- (v) Use the cumulative frequency polygon to find an estimate for the interquartile range. **2**

QUESTION 18. *Start a new sheet of paper.*

Marks

- (a) Tom surveyed one of his pasture paddocks using an offset survey. His notebook entry of this survey is shown below. All measurements are in metres.

	C	
	61	
	49	12 B
D 25	23	
E 20	9	
	0	
	A	

- (i) Make a neat sketch of the paddock. Mark all measurements on your diagram. 2
- (ii) Find the area of the paddock correct to the nearest metre. 3
- (b) Heath's car has a fuel tank with a measured capacity of 45 litres. If this measurement is given to the nearest litre, find its percentage error. 2
- (c) A tank has the shape of an octagonal prism. Its cross-section, A, is an irregular octagon as shown in the diagram below, formed by cutting identical right-angled triangles from the corners of a square. 2

Cross Section

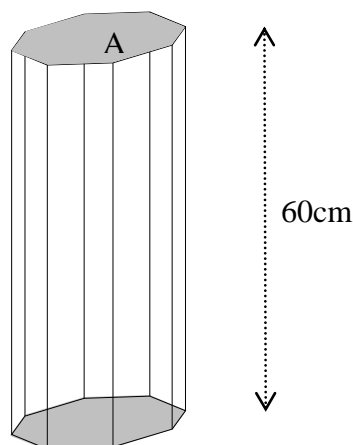
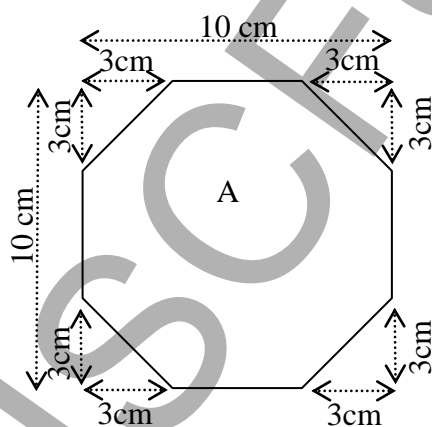

Diagram not to scale

- (i) Find the area, A, of the octagon. 2
- (ii) Calculate the capacity of the tank to the nearest millilitre. 2
- (iii) If the base and the top of the tank are made of plastic and the remaining side faces made of glass, find the total surface area of the glass. 2

QUESTION 19. *Start a new sheet of paper.*

Marks

- (a) Emma takes out a reducing balance loan to borrow \$170 000 to purchase a 2-bedroom unit. The loan is charged at 6% p.a. calculated monthly and the monthly repayment is \$1095.

The table below shows the progress of her loan.

Home loan table				
	Amount	\$170 000	This table assumes the same number of days in each month. i.e. Interest = Rate/12 x Principal.	
	Annual interest rate	6%		
	Monthly repayment	\$1095		
Month (N)	Principal (P)	Interest (I)	P + I	P + I - R
1	\$170,000.00	\$850.00	\$170,850.00	\$169,755.00
2	\$169,755.00	\$848.78	\$170,603.78	\$169,508.78
3	\$169,508.78	\$847.54	\$170,356.32	\$169,261.32
4	\$169,261.32	\$846.31	\$170,107.63	\$169,012.63
5	\$169,012.63	\$845.06	\$169,857.69	\$168,762.69
6	\$168,762.69	A	B	C
303	\$1,304.95	\$6.52	\$1,311.48	\$216.48
304	\$216.48			

- (i) Find the three missing amounts A, B and C for the 6th month. **3**
- (ii) How much of the principal has been paid off after 6 months? **1**
- (iii) After the 304th monthly payment, Emma paid off her loan completely. Use the table to calculate the value of Emma's last payment. **2**
- (iv) Calculate the total amount Emma paid over the 304 months. **1**
- (v) Convert 304 months to years and months. **1**

Question 19 continues next page.

QUESTION 19 (continued).

Marks

- (b) Anton's credit card account has a 30 days interest-free period. There is no interest charged as long as Anton makes the payment by the due date. Otherwise, interest is charged at 18% p.a. for every item *from the date of purchase*.

Anton's monthly statement is shown below.

Statement of Account		Statement start date:	18 Jan 2003
		Statement end date:	14 Feb 2003
		Due date:	11 Mar 2003
Credit limit	\$1500	Annual interest rate	18%
Available credit	\$ B	Daily interest rate	0.0492%
		Purchases	\$255.80
		Cash advances	\$80.00
Date	Transaction details	Amount (\$)	
20 Jan	Chess Set Big W	\$34.80	
23 Jan	Petrol BP	\$27.50	
31 Jan	Optus card Optus	\$40.00	
2 Feb	Cash Advance Westpac	\$80.00	
5 Feb	Food Go Lo	\$43.20	
12 Feb	Dance Class Twinkle Dance Company	\$110.00	
Closing balance		\$ A	

- (i) Find the values of A and B, the closing balance and the available credit. **2**
- (ii) How was the daily interest rate of 0.0492% calculated? **1**
- (iii) Anton pays the closing balance on 15 March, 2003.
Count the number of days of interest he will be charged for his petrol purchase. **1**
- (iv) Hence calculate the interest he was charged on his petrol purchase. **1**

QUESTION 20. *Start a new sheet of paper.***Marks**

- (a) Solve $(4 \cdot 2)^x = 20$ for x , correct to 2 decimal places. **2**
- (b) The volume of a steel ball bearing is $5 \cdot 964 \text{ mm}^3$.
If it has the shape of a sphere, then find its radius correct to 3 decimal places. **2**
- (c) Tessa believes there is a linear relationship between the temperature and the number of students playing touch football at school at lunchtime that day. She collected the following data, where T stands for the temperature (in degrees Celsius) and N stands for the number of students playing touch football.

T ($^{\circ}\text{C}$)	19	20	22	23	24	26	27
N	35	32	22	23	17	13	9

- (i) Use the graph paper supplied on page 15 to carefully plot these points on a number plane and draw a line of best fit.
(Tear off page 15 and include it with your answers for Question 20) **2**
- (ii) Find the equation of your line of best fit in the form $y = mx + b$, expressing m and b correct to 2 decimal places if needed. **3**
- (iii) According to your linear model, about how many students would you expect to play on a day when the temperature is 25°C ? **1**
- (iv) According to your linear model, when the temperature rises 1 degree, approximately how many fewer students play football at lunchtime? **1**
- (v) Explain why your linear model has its limitations for lower and higher values of T. **2**

END OF TEST.

Use this graph for Question 20 (b)

Name:.....

Class:.....

