

2011

**SEMESTER 1 EXAMINATION
EXAMINATION**

Student Number

General Mathematics



General Instructions

- Reading time – 5 minutes
- Working time – $2\frac{1}{2}$ hours
- Write using blue or black pen
- Calculators may be used
- A formulae sheet is provided at the back of this paper

Total Marks – 100

Section 1:

22 marks

- Attempt questions 1-22
- Allow about 30 minutes for this section

Section 2:

78 marks

- Attempt questions 23-28
- Allow about 2 hours for this section

SECTION 1

22 marks

Attempt Questions 1 to 22.

Allow about 30 minutes for this section.

Use the multiple-choice answer sheet for Questions 1-22.

1. The simple interest payable on a loan of \$2380 at a simple interest rate of 7.45% p.a. for a period of 17 months is closest to:

(A) \$ 149.50 (B) \$251.20 (C) \$ 2481.90 (D) \$101.90

2. Jeneve has 4500 shares with the market value of \$3.60 each. In the last year she received a total dividend of \$320. What is the dividend yield on these shares?

(A) 0.0196% (B) 1.1% (C) 2.0% (D) 7.1%

3. How many significant figures are there in the decimal 0.02054

(A) 2 (B) 3 (C) 4 (D) 5

4. What is the median of this set of data?

Stem	Leaf
1	0 2
3	1 4 4 8
4	2 3
5	2 2
6	8 9

(A) 38 (B) 40 (C) 42 (D) 43

5. Examine the following diagram. The interquartile range is:

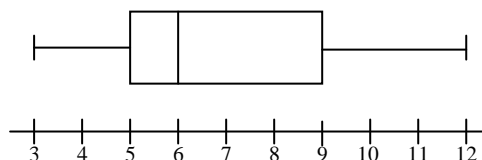

(A) 4 (B) 6 (C) 8 (D) 9

6. What is the area of the triangle to the nearest square metre?

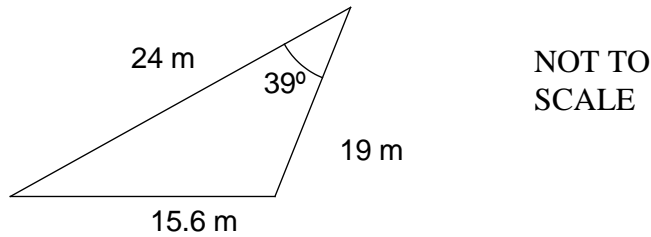

- (A) $93m^2$ (B) $118m^2$ (C) $143m^2$ (D) $287m^2$

7. There are 600 students at a local high school. In Year 12 there are 120 students. If 150 students are chosen for a survey using stratified sampling, how many Year 12 students will need to be surveyed?

- (A) 12 (B) 20 (C) 30 (D) 120

8. The lengths of TWO pieces of timber are measured to be 1.7 m and 3.2 m respectively. What is the upper limit of their lengths when they are placed end to end?

- (A) 4.85 m (B) 4.9 m (C) 4.95 m (D) 5.0 m

9. David calculated the present value of an annuity to be \$50 000. Given the interest rate is 8% p.a., compounded monthly, which calculation will produce the correct answer for the future value of the annuity in 5 year's time?

- (A) $A = 50000(1 + 0.08)^5$ (B) $A = 50000(1 + 0.08 \div 12)^5$
 (C) $A = 50000(1 + 0.08)^{5 \times 12}$ (D) $A = 50000(1 + 0.08 \div 12)^{5 \times 12}$

10. Using Simpson's rule, calculate the length (x) of the base, if the area of the piece of land is $284m^2$.

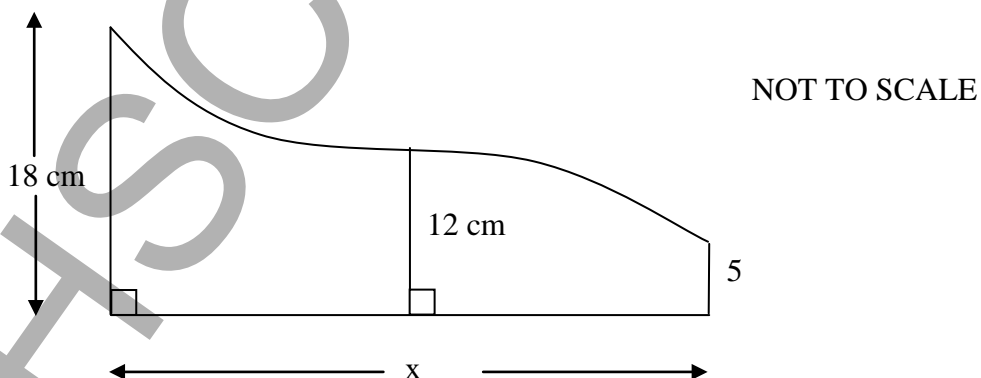

- (A) 9 cm (B) 12 cm (C) 24 cm (D) 30 cm

11. Simplify $5(x^2 + 2x) - 3x(x - 4)$
- (A) $8x^2 + 22x$ (B) $2x^2 + 22x$ (C) $2x^2 - 2x$ (D) $15x^3 - 3x^2 + 12x$

12. Arabella takes out a flat rate loan of \$5600 and repays the loan with monthly repayments over 3 years. Interest is charged at 9% p.a. The total amount that Arabella must repay is:

- (A) \$197.56 (B) \$1512 (C) \$5600 (D) \$7112

13. A tin of Mathspaint comes in one size only and covers 1 m^2 on the average. How many tins of Mathspaint would you need to paint the wooden gate below?

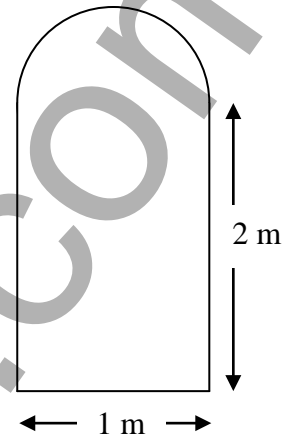

- (A) 1 (B) 2
(C) 3 (D) 4

14. A store retailing refrigerators has advertised interest-free terms up to 2 years. Ryan decides to buy a new refrigerator for \$600.

The conditions are:

- 25% deposit
- monthly repayments of at least \$18.75

Ryan decides to make repayments of \$30 per month. The minimum time it will take Ryan to pay off the interest-free loan is

- (A) 12 months (B) 15 months (C) 20 months (D) 24 months

15. The expression for the area of this sector is:

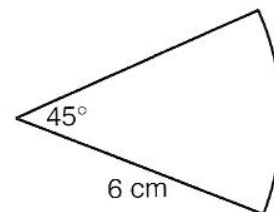

- (A) $\frac{45}{360} \times \pi \times 6^2$ (B) $\frac{6}{360} \times \pi \times 45^2$
(C) $\frac{45}{360} \times 2 \times \pi \times 6^2$ (D) $\frac{\pi \times 6^2}{360}$

16. The following table shows the income tax rate for Australian residents for the 2005-06 financial year.

<i>Taxable income</i>	<i>Tax Payable on Taxable Income</i>
\$0 – \$6,000	Nil
\$6,001 – \$25,000	15c for each \$1 over \$6,000
\$25,001 – \$75,000	\$2,850 plus 30c for each \$1 over \$25,000
\$75,001 – \$150,000	\$17,850 plus 40c for each \$1 over \$75,000
Over \$150,000	\$47,850 plus 45c for each \$1 over \$150,000

At the end of the financial year Lochie was required to pay income tax of \$21 251.94

What was Lochie's taxable income?

- (A) \$6491 (B) \$15 475 (C) \$78 457 (D) \$83 505
17. The table below shows the future value of an investment of \$1 in an ordinary annuity.

Period	Interest Rate per Period				
	1%	2%	3%	4%	5%
1	1.0000	1.0000	1.0000	1.0000	1.0000
2	2.0100	2.0200	2.0300	2.0400	2.0500
3	3.0301	3.0604	3.0909	3.1216	3.1525
4	4.0604	4.1216	4.1836	4.2465	4.3101
5	5.1010	5.2040	5.3091	5.4163	5.5256
6	6.1520	6.3081	6.4684	6.6330	6.8019
7	7.2135	7.4343	7.6625	7.8983	8.1420
8	8.2857	8.5830	8.8923	9.2142	9.5491

Laura invests \$3000 at the end of each year for 5 years at 4% p.a. Using the table above, find the value of her annuity at the end of 5 years.

- (A) \$12 739.50 (B) \$12 930.30
 (C) \$16 248.90 (D) \$16 576.80
18. A survey looked at the eye colour of 100 Australians. Which term best describes the data?
- (A) Discrete (B) Stratified
 (C) Categorical (D) Continuous

19. A table's height is 120cm. The percentage error, to 1 significant figure, given the tape measure used to measure the table is graduated in centimetres is:
- (A) $\pm 0.004\%$ (B) $\pm 0.4\%$ (C) $\pm 0.5\%$ (D) $\pm 50\%$
20. The daily costs of running a small factory is \$800 for staff wages and \$25 per hour to run the machinery. The total daily cost in dollars (C) can be expressed in terms of the number of hours (h) that the machinery operates. Which equation best represents this information?
- (A) $C = 825h$ (B) $C = 800 + 25h$
(C) $C = 25h$ (D) $C = 825$
21. In NSW, postcodes consist of four digits, with the first number always a '2'. The number of distinct possible postcodes is given by:
- (A) 2^4 (B) $2 \times 10 \times 9 \times 8$ (C) 10^3 (D) 10^4
22. The effective interest rate (E) charged on a loan in relation to the stated rate (r) is given by the formula
- $$E = \frac{(1+r)^n - 1}{n}$$
- where E (the effective interest rate) is expressed as a decimal and n is the time period.
Don't Pay More Pty Ltd offers credit at a rate of 15% p.a. reducible for a loan spread over 5 years.
The effective interest rate, calculated as a flat rate of interest, would be closest to:
- (A) 19 % (B) 20 % (C) 22 % (D) 21 %

End of Section I

SECTION 2

Question 23 (13 marks)

Use the Question 23 writing booklet.

Marks

- (a) Kurt has a credit card which has an interest rate of 18.25% per annum.
- (i) Convert the interest rate to a daily percentage rate. 1
- (ii) Kurt has an outstanding balance of \$975 for a period of twenty-four days. How much interest will he be charged? 1
- (b) The repayment schedule for a reducing balance loan, with interest compounded monthly, is shown in the table below.

Amount of Loan = \$50 000
Annual Interest Rate = 7.8%
Monthly Repayment (R) = \$600

Period	Principal (P)	Interest (I)	P + I	P + I - R
1	\$50 000.00	50000×0.0065 = \$325.00	\$50 325.00	\$49 725.00
2	\$49 725.00	\$323.21	\$50 048.21	\$49 448.21
3	\$49 448.21	A	B	\$49 169.62
4	\$49 169.62	\$319.60	\$49 489.22	\$48 889.22
5	\$48 889.22	\$317.78	\$49 207.00	\$48 607.00

- (i) Explain why the number 0.0065 is used in calculating the monthly interest. 1
- (ii) Calculate the values of **A** and **B** in the table. 2
- (c) Shenayd asks your advice about a choice of investments. She could invest \$80 000 today at 12% p.a. compounded annually for 10 years.
- Alternatively she could make monthly payments of \$1500 for 5 years at 12% p.a. compounded monthly. At the end of these 5 years she would not make any more monthly payments, but let the accumulated amount be invested for another 5 years at 12% p.a. compounded annually.
- (i) Calculate the amount that \$80 000 becomes when compounded annually at 12% p.a. for 10 years. 1
- (ii) Calculate the amount the alternative investment will reach after the first 5 years. 2
- (iii) Which of the two types of investments mentioned above would you advise Shenayd to choose? Explain your answer carefully. 2

QUESTION 23 CONTINUES

- (d) The value of a Vespa Scooter when purchased new is \$6 500. The scooter depreciates at a rate of 15% p.a. under declining balance depreciation.
- (i) Calculate the salvage value of the Vespa Scooter after 5 years. 1
- (ii) Calculate the equivalent rate of straight line depreciation over the 5 years. 2

End of Question 23

HSCFOCUS.COM

Question 24 (13 marks)

Use the Question 24 writing booklet.

Marks

- (a) Tayla wants to start saving for her granddaughter's education from the day she is born. 3

She plans to invest \$500 each month from her birth date, at 6% p.a. compounded monthly.

After how many years and months, will there be at least \$15000 in the account to pay for her granddaughter's private school fees?

- (b) The Eastpac Bank publishes the following loan repayment table showing the monthly repayment amount for each \$1000 borrowed.

Interest Rate p.a.	Term in years				
	5	10	15	20	25
5%	\$18.87	\$10.61	\$7.91	\$6.60	\$5.85
6%	\$19.33	\$11.10	\$8.44	\$7.16	\$6.44
7%	\$19.80	\$11.61	\$8.99	\$7.75	\$7.07
8%	\$20.28	\$12.13	\$9.56	\$8.36	\$7.72
9%	\$20.76	\$12.67	\$10.14	\$9.00	\$8.39
10%	\$21.25	\$13.22	\$10.75	\$9.65	\$9.09
11%	\$21.74	\$13.78	\$11.37	\$10.32	\$9.80
12%	\$22.25	\$14.35	\$12.00	\$11.01	\$10.53

Charles borrowed \$105 000 to purchase a boat. The loan is to be repaid at 12% p.a. over 25 years.

- (i) Calculate Charles' monthly repayment. 1
- (ii) Find the total amount Charles pays over the term on the loan. 1
- (iii) How much would Charles have saved by paying the loan over 10 years rather than 25 years? 2

QUESTION 24 CONTINUES

- (c) George has been given \$5000 for his 18th birthday. He is trying to decide on the best way to invest this money for 10 years.

The first deal is to invest this money in a savings account at the local bank which offers 7% per annum simple interest.

The growth of \$5000 invested at 7% is shown in the graph below, where V is the amount after n months.

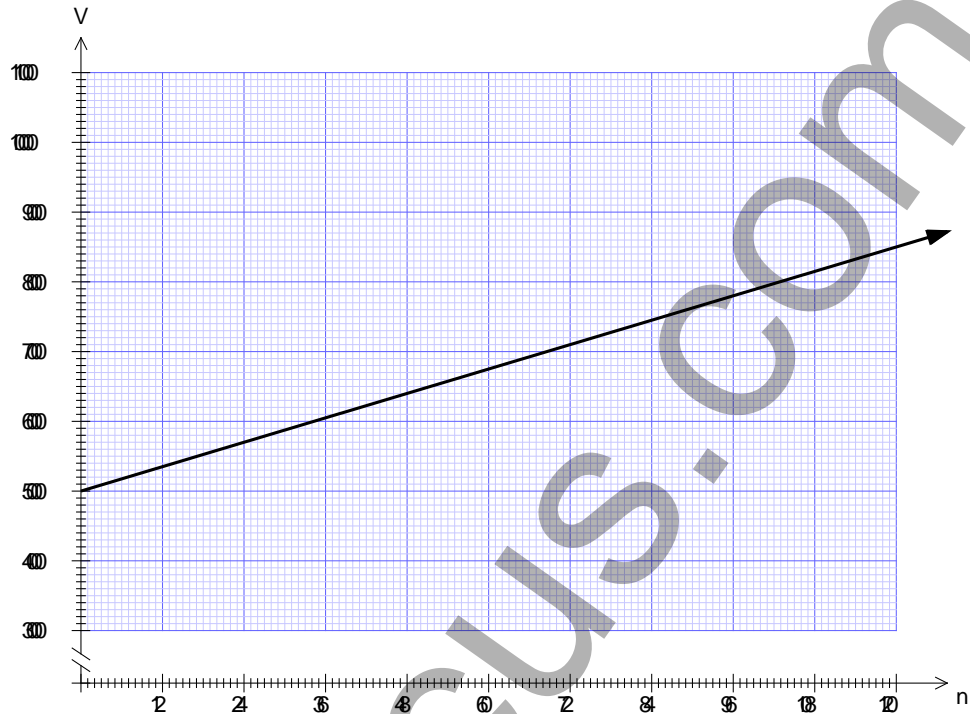

- (i) Use the graph to determine the amount George will have after 10 years. Give your answer to the nearest \$100 dollars. 1
- (ii) How much interest did George earn? 1
- (iii) What is the equation of this straight line? 1

George finds another bank that offers him 5.9% per annum compounded monthly. He decides to use his General Maths knowledge to find out which is the better option.

QUESTION 24 CONTINUES

- (iv) In the answer booklet, complete the table for the compound interest scenario.

1

Number of Months (n)	Value of investment to the nearest dollar (V)
0	5000
12	5303
24	5625
36	5966
60	
84	7549
120	

- (v) The graph above has been copied in your answer booklet.
On the same set of axes, plot the graph for the table of values in (iv).

1

- (vi) Clearly the compound interest option is far better if George is going to invest the money for 10 years.
Use the graph to determine the number of months George needs to invest his money for the compound interest to be the best option.

1

End of Question 24

Question 25 (13 marks)

Use the Question 25 writing booklet.

Marks

- (a) Jocelyn wants to build a pool in the backyard with a sun deck in the middle.

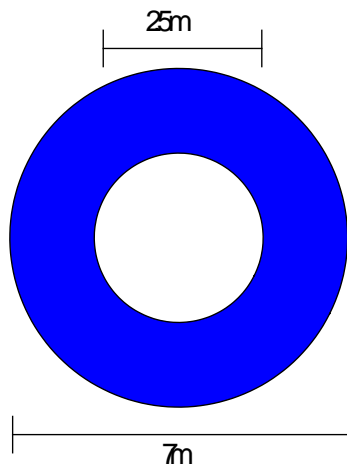

The pool has a diameter of 7m and the sun deck has a diameter of 2.5m.

Jocelyn wants to buy a cover for the pool. She can get the material made into any shape. The material costs \$40 per m^2 .

2

How much will it cost to have the cover made? (to the nearest cent)

QUESTION 25 CONTINUES

(b)

Charlie has won Lotto and bought a small island.

3



For tax reasons he needs to work out the area of the island. He decides to make some measurements to help him find the area.

Using the Simpson Rule determine the area of the island.

(c)

Kathryn decides to build a rectangular hutch for her rabbits.

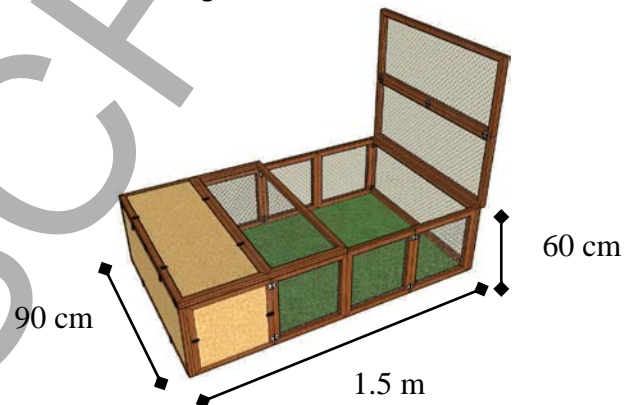

(i) The plans ask for the hutch to be 1.5m long, 60 cm high and 90 cm wide. If Kathryn measures everything to the nearest cm what is the upper bound of the volume?

3

(ii) If she doubles the length of each measurement, by what percentage does the volume increase?

2

QUESTION 25 CONTINUES

(d) Madeline wants to put a bird bath in her back yard.

The base has a 0.6 m diameter and is 0.9 m high. The bowl on top has the same diameter as the base.

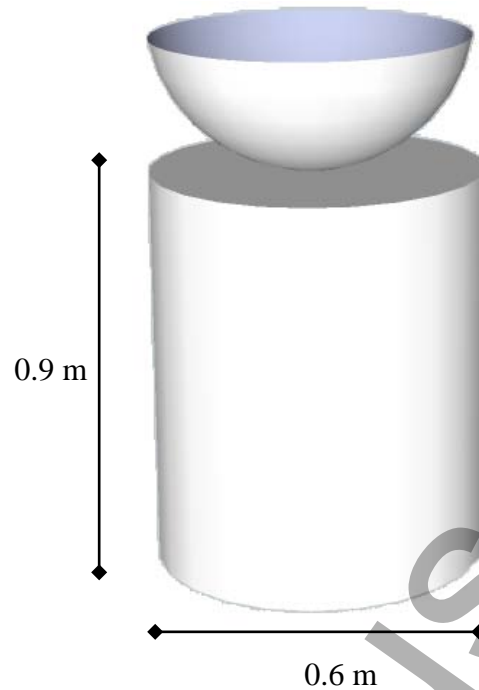

Madeline needs to paint the exposed areas of the base (not the bottom) and the outside of the bowl. Calculate the total area that will be painted.

2

If the paint coverage is 1L per 15 m^2 what percentage of a 1L paint tin would Madeline use, correct to three significant figures?

1

End of Question 25

Question 26 (13 marks)

Use the Question 26 writing booklet.

Marks

(a)

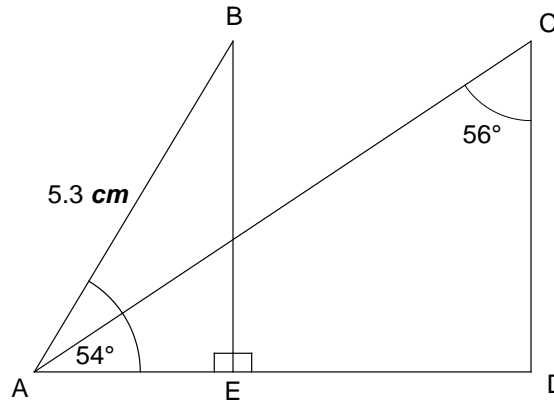

Line AB is 5.3 cm long.

Angle $\angle BAE$ is 54° and $\angle ACD$ is 56°

- (i) Show that the length of BE is approximately 4.29 cm long. 1
- (ii) Hence or otherwise find the length of ED to 3 significant figures. 3
(HINT Find the length of AE first)

(b)

The swimming leg of a triathlon race follows a triangular course.

The bearing of the Start to check point B is $27^\circ T$. From check point A to check point B is 812 m long. The distance from check point B to the finish is 600 m.

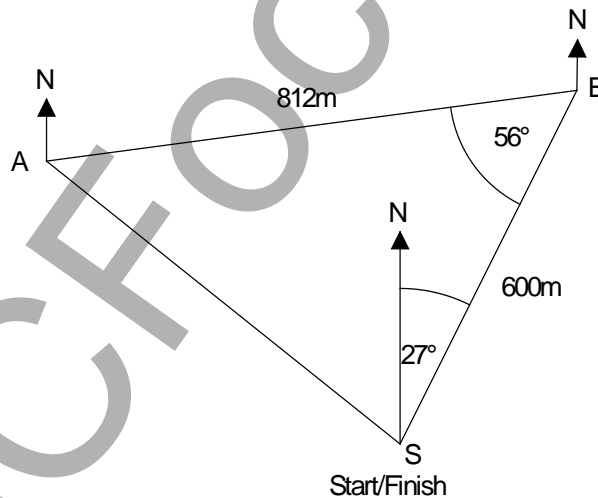

- (i) Determine the bearing of check point A from check point B. 1
- (ii) Show that the length of the Start (S) to check point A is 689 m (to the nearest metre) 2
- (iii) Calculate the angle of $\angle BAS$ 2
- (iv) William swims at an average speed of 3.5 km/h over the race. How long did it take William to finish the race to the nearest minute? 1

QUESTION 26 CONTINUES

- (c) Klara is going to sculpt the great Egyptian Pyramid and a rectangular prism stand using a single block of sandstone. She starts with a piece that is made up from a rectangular prism and a square pyramid as is shown below.

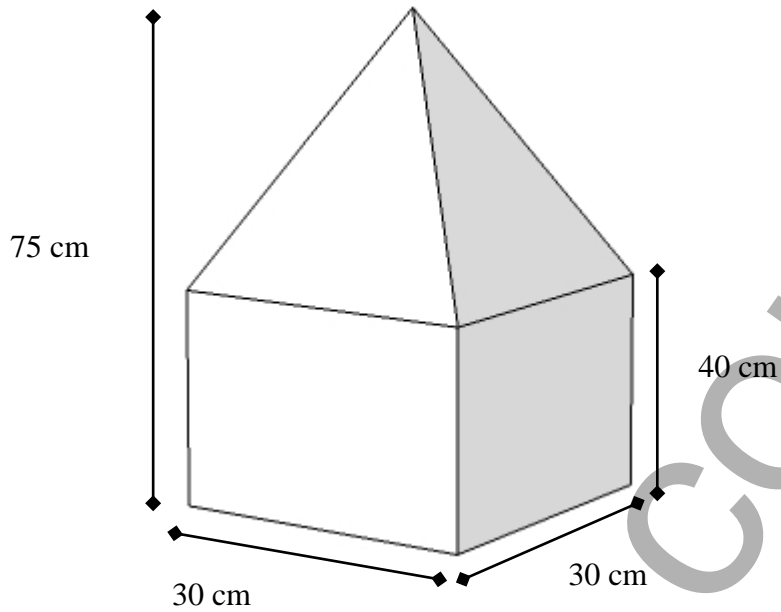

- (i) Determine the volume of the sandstone block pictured above. 2
- (ii) It costs \$500 per cubic metre for a sandstone block shaped the way Klara wants it. How much is going to cost her to buy this block? 1

End of Question 26

Question 27 (13 marks)

Use the Question 27 writing booklet.

Marks

- (a) A scientific study uses the 'capture-recapture' technique. In the first stage of the study, 60 crocodiles were caught, tagged and released. Later, in the second stage of the study, some crocodiles were captured from the same area. 24 of these were found to be tagged, which was 30% of the total captured during the second stage.
- (i) How many crocodiles were captured in total during the second stage of the study? **1**
- (ii) Calculate the estimate for the total population of crocodiles in this area. **2**
- (b) Give an example of an event that has the probability of exactly $\frac{2}{3}$ **1**
- (c) The formula $D = \frac{5W}{18}$ is used to calculate the dosage of Cofugutsup cough medicine to be given to a child.
- D is the dosage of Cofugutsup cough medicine in millilitres (mL).
 - W is the weight of the child in kilograms.
- (i) Brad is a new dad and wants to make sure that his new baby Oliver gets the right dosage. If Oliver weighs 7.2kg what dosage should Brad give Oliver? **1**
- (ii) The correct dosage of Cofugutsup for David is 3.2 mL. What is the difference in weight between David and Oliver correct to 1 decimal place? **3**
- (d) (i) Calculate the five point summary for the following set of scores **2**
- 54 47 53 45 68 66 55 72 61 48
- (ii) The mean for the set of scores above is 56.9.
Find **two** whole numbers that can be added to the list to make a new mean of 60.
Show working to justify your answer. **2**
- (iii) Explain why this set of scores could not be categorical data. **1**

End of Question 27

Question 28 (13 marks)

Use the Question 28 writing booklet.

Marks

(a) Simplify

2

$$\frac{df^2}{4b} \div \frac{6f}{b}$$

(b) A pin is a four digit number such as 3472.

(i) If all ten digits are available how many different pins can be generated?

1

(ii) Simranjeet has just got a new ATM card with a four digit pin. When he gets to the ATM he can only remember that the number starts with a 5 and ends with a 7 or 6. What is the probability that Simranjeet will get his pin correct in the first try?

1

(c) Patrick records the average weight of a random sample of the people at his work. He records this on a cumulative frequency histogram

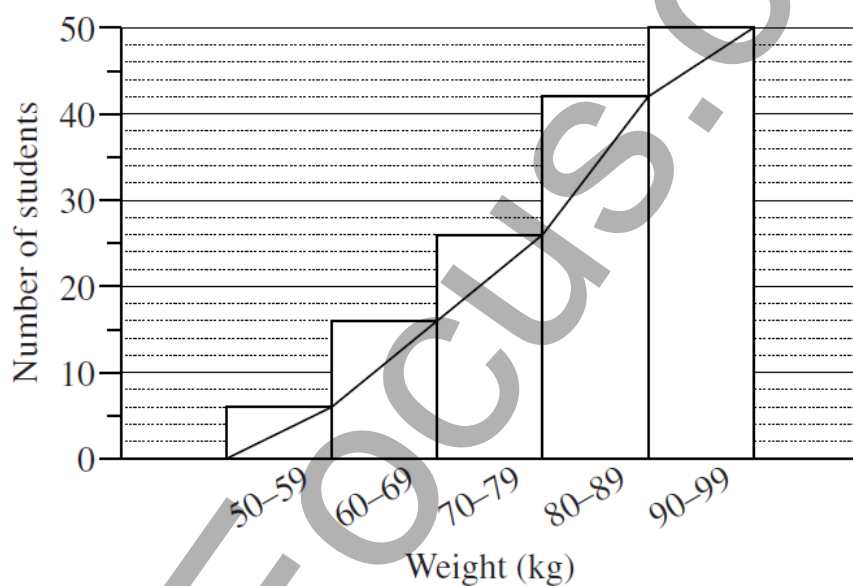

(i) How many of Patricks work mates fit into the 90-99kg category?

1

(ii) If 400 people work at Patricks work, how many would you expect to weigh less than 70kg?

2**QUESTION 28 CONTINUES**

- (d) George completes an offset survey to construct a sketch a diagram ABCD of his new block of land.
 George walks from A to C, a distance of 54 m.
 When he is 14 m from A, he notes that point D is 10 m to his right.
 When he is 37 m from A, he notes that point B is 32 m to his left.
 This is his field note book entry

	C	
	54	
B 32	37	
	14	10 D
	0	
	A	

- (i) Draw a neat diagram of the block of land in your answer booklet. Ensure that you label the points A, B, C, and D. 1
- (ii) Calculate the length of B to C correct to 2 decimal places. 2
- (e) George decides to add a sprinkler system to his new block of land.
 He uses water collected off the roof of his house to fill a tank.
- (i) The size of George's roof is 50 m^2 . In a storm 90 mm of rain falls on the roof. How much water did George collect in the storm to the nearest litre? 2
- (ii) If the tank was empty at the beginning of the storm and 60% full at the end of the storm what is the capacity of the tank? 1

End of Paper