



CATHOLIC SECONDARY SCHOOLS
ASSOCIATION OF NEW SOUTH WALES

--	--	--	--	--

Centre Number

--	--	--	--	--	--	--	--	--	--

Student Number

2009
TRIAL HIGHER SCHOOL CERTIFICATE
EXAMINATION

General Mathematics

Morning Session
Monday 17 August 2009

General Instructions

- Reading time – 5 minutes
- Working time – 2½ hours
- Write using blue or black pen
- Calculators may be used
- Use Multiple Choice Answer Sheet provided
- A separate Formula Sheet is provided
- Write your Centre Number and Student Number at the top of this page, Multiple Choice Booklet and all Writing Booklets

Total marks: 100

Section I Pages 2–8

22 marks

- Attempt Questions 1–22
- Allow about 30 minutes for this section

Section II Pages 9–20

78 marks

- Attempt Questions 23–28
- Allow about 2 hours for this section

Disclaimer

Every effort has been made to prepare these 'Trial' Higher School Certificate Examinations in accordance with the Board of Studies documents, *Principles for Setting HSC Examinations in a Standards-Referenced Framework* (BOS Bulletin, Vol 8, No 9, Nov/Dec 1999), and *Principles for Developing Marking Guidelines Examinations in a Standards Referenced Framework* (BOS Bulletin, Vol 9, No 3, May 2000). No guarantee or warranty is made or implied that the 'Trial' Examination papers mirror in every respect the actual HSC Examination question paper in any or all courses to be examined. These papers do not constitute 'advice' nor can they be construed as authoritative interpretations of Board of Studies intentions. The CSSA accepts no liability for any reliance, use or purpose related to these 'Trial' question papers. Advice on HSC examination issues is only to be obtained from the NSW Board of Studies.

6100-1

Section I

22 marks

Attempt Questions 1–22

Allow about 30 minutes for this section

Use the multiple-choice answer sheet.

1

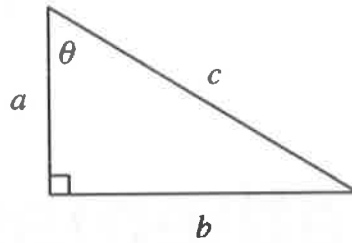

What is the correct expression for $\sin \theta$ in this triangle?

- (A) $\frac{a}{b}$
- (B) $\frac{b}{a}$
- (C) $\frac{b}{c}$
- (D) $\frac{c}{b}$
- 2 The first question of a survey states "Which colour car do you prefer?" This question will produce what type of data?
- (A) Categorical
- (B) Continuous
- (C) Discrete
- (D) Numerical

- 3 Jake is one of the five school leaders who are having their group photo taken. They are going to be seated randomly in a single row. What is the probability that, for the photograph, Jake will be seated on either end?
- (A) $\frac{2}{5}$
(B) $\frac{1}{25}$
(C) $\frac{1}{20}$
(D) $\frac{4}{25}$
- 4 Lauren is buying a new car. The cash price is \$15 990. She decides to buy the car on terms of 30% deposit and 18 monthly payments of \$680. How much more does Lauren pay when she buys the car on terms compared to paying cash?
- (A) \$1047
(B) \$3750
(C) \$8547
(D) \$17 037
- 5 Tom earns \$14.50 per hour normal rate. How much does he earn if he works 38 hours at normal rate and 5 hours at time-and-a-half?
- (A) \$587.25
(B) \$630.75
(C) \$659.75
(D) \$935.25
- 6 Expand and simplify: $2x(7 - x) - x(x - 1)$
- (A) $13x - x^2$
(B) $14x - 2x^2$
(C) $14x - 3x^2 + 1$
(D) $15x - 3x^2$

The box-and-whisker plot below represents the number of calls made to find a casual teacher for the day. Use this information to answer questions 7 and 8.

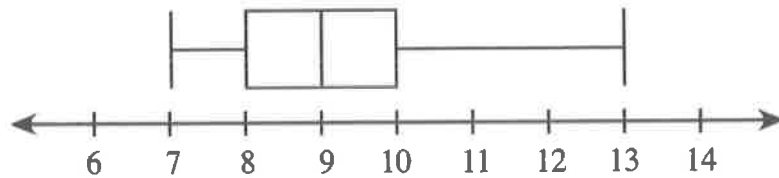

- 7 Which of the following must be correct?
- (A) The median is 9
 - (B) The mode is 9
 - (C) The mean is 9
 - (D) The interquartile range is 9
- 8 The distribution of the data shown in the box-and-whisker plot is best described as
- (A) negatively skewed.
 - (B) normal.
 - (C) positively skewed.
 - (D) symmetrical.
- 9 The number (n) of eggs used in a recipe for a particular cake varies with the square of the diameter (d) of the tin. The equation to show this relationship is
- (A) $n^2 = kd$
 - (B) $n = kd^2$
 - (C) $n^2 = \frac{k}{d}$
 - (D) $n = \frac{k}{d^2}$

- 10 There are 12 students in the senior Drama class. Two are selected at random to participate in a regional performance. How many different pairs of students could be selected?
- (A) 12
 - (B) 66
 - (C) 132
 - (D) 144

- 11 The length of the cross-sectional diagonal (d) of a cube is given by:

$$d = \sqrt{3s^2}$$

where s is the length of each side of the cube. Which of the following correctly gives the length of each side of the cube?

- (A) $s = \frac{d}{3}$
 - (B) $s = \frac{d^2}{3}$
 - (C) $s = \sqrt{\frac{d}{3}}$
 - (D) $s = \sqrt{\frac{d^2}{3}}$
- 12 The co-ordinates of Cloncurry are latitude 21°S and longitude 141°E . Collinsville is due east of Cloncurry. Which of the following could be the latitude and longitude of Collinsville?
- (A) $21^\circ\text{S}, 141^\circ\text{E}$
 - (B) $21^\circ\text{S}, 148^\circ\text{E}$
 - (C) $29^\circ\text{S}, 141^\circ\text{E}$
 - (D) $29^\circ\text{S}, 148^\circ\text{E}$

- 13 The pulse rates of a large group of 18-year-old students are normally distributed with a mean of 75 beats per minute and a standard deviation of 11 beats per minute. The percentage of 18-year-old students with pulse rates less than 86 beats per minute is closest to:
- (A) 16%
 - (B) 68%
 - (C) 84%
 - (D) 97.5%
- 14 Charlotte measures the base and perpendicular height of a parallelogram to the nearest centimetre. Her answers are 8 cm and 6 cm. Between which lower and upper values must the actual area of the parallelogram lie?
- (A) 48 cm^2 and 63 cm^2
 - (B) 48 cm^2 and 55.25 cm^2
 - (C) 41.25 cm^2 and 48 cm^2
 - (D) 41.25 cm^2 and 55.25 cm^2
- 15 An iPhone was purchased for \$825. The price included 10% GST. The amount of GST included in the price was:
- (A) \$75.00
 - (B) \$82.50
 - (C) \$90.75
 - (D) \$125.00
- 16 Mitchell measured his height to be 182 cm, correct to the nearest centimetre. What is the percentage error in his measurement?
- (A) $\pm 0.0027\%$
 - (B) $\pm 0.0055\%$
 - (C) $\pm 0.27\%$
 - (D) $\pm 0.55\%$

- 17 The times for 25 runners in a fun run ranged between 15.3 minutes and 18.7 minutes. The 26th runner had a time of 31.2 minutes. Which of the following would be most affected by this score?
- (A) The mode
 - (B) The median
 - (C) The interquartile range
 - (D) The mean

18

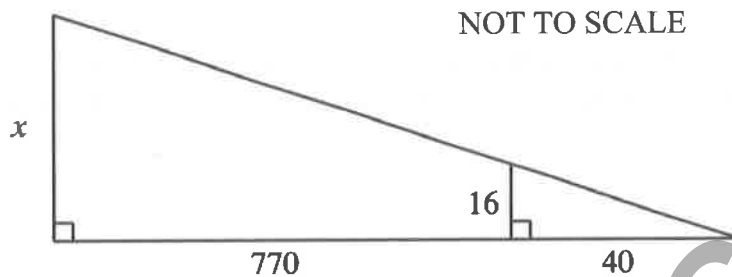

The value of x in the diagram above is closest to

- (A) 202
 - (B) 308
 - (C) 324
 - (D) 746
- 19 In Maitland during August, the probability of rain on any particular Saturday is 0.6 and the probability of rain on any particular Sunday is 0.3. What would be the probability of two days **without rain** in Maitland next weekend?
- (A) 12%
 - (B) 18%
 - (C) 28%
 - (D) 42%

- 20 The following table shows the monthly repayments per \$100 000 borrowed with reducible interest and monthly repayments.

Interest Rate (% p.a.)	Term of Loan				
	5 years	10 years	15 years	20 years	25 years
6.50	1956.61	1135.48	871.11	745.57	675.21
6.75	1968.35	1148.24	884.91	760.36	690.91
7.00	1980.12	1161.08	898.83	775.30	706.78
7.25	1991.94	1174.01	912.86	790.38	722.81
7.50	2003.79	1187.02	927.01	805.59	738.99
7.75	2015.70	1200.11	941.28	831.79	755.33

- Michael bought a house for \$450 000. He borrowed the amount at 6.75% p.a. interest. The loan was to be repaid monthly over 20 years. Using the table above, the **total amount** that Michael pays is closest to
- (A) \$68 432
(B) \$69 777
(C) \$821 189
(D) \$837 324
- 21 Given that $\Delta = b^2 - 4ac$, then the value of b when $\Delta = 8.1 \times 10^7$, $a = 3.9 \times 10^8$ and $c = 5.4$ is closest to:
- (A) 9.13×10^4
(B) 9.22×10^4
(C) 8.34×10^9
(D) 8.51×10^9
- 22 A game involves spinning a wheel with the numbers 1 to 40 on it. If the ball lands on a number divisible by 11 you win \$10. If it lands on a number divisible by 10 you win \$5. If it lands on any other number you lose \$2. What is the **financial expectation** of this game?
- (A) Lose 40¢
(B) Win \$2.90
(C) Win \$10
(D) Lose \$2

Section II

78 marks

Attempt Questions 23–28

Allow about 2 hours for this section

Answer each question in a SEPARATE writing booklet. Extra writing booklets are available.

All necessary working should be shown in every question.

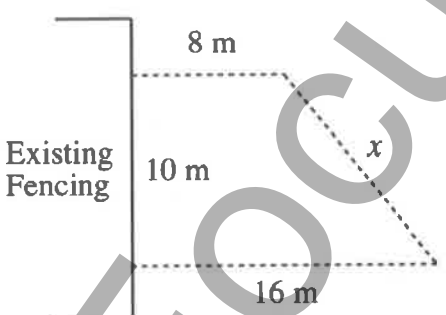
-
- Marks**
- Question 23** (13 marks) Use a SEPARATE writing booklet.
- (a) The weights of four members of a sailing crew are 47 kg, 52 kg, 57 kg and 57 kg.
- (i) Calculate the mean weight of the four sailors. 1
- (ii) A fifth sailor joins the crew. The mean weight is now 51 kg. Find the weight of the fifth sailor. 2
- (b)
- 
- The diagram above is a sketch for a play area that a restaurant is planning to build.
- (i) Find the value of x . Give your answer correct to the nearest metre. 2
- (ii) Find the length of fencing required for the play area. 1
- (c) Park rangers were required to determine the population of fish in their local waterway. The rangers caught 30 fish, tagged them and released them back into the waterway. The following month they returned to the waterway. They caught 72 fish and found 9 to be tagged. Using the capture-recapture technique, find an estimate for the population of fish in the waterway. 2
- (d) The time in Town A is 11 am on Sunday 7th February. The time in Town B is 10 pm on Saturday 6th February. What is the angular distance between the towns? 2

Question 23 continues on Page 10

Question 23 (continued)

- (e) Ja'mie is organising her 17th birthday party. She is having invitations specially printed at Hilford Party Supplies. Their printing charges are shown in the graph below.

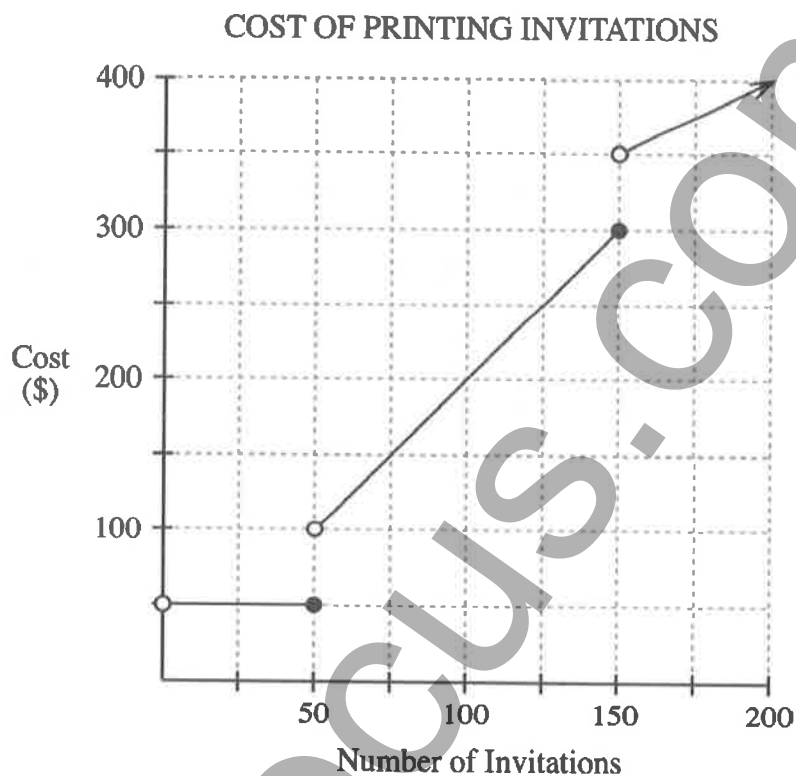

- (i) Find the cost of printing 150 invitations. 1
- (ii) Ja'mie has a budget of \$250 for printing. How many invitations can she afford to order? 1
- (iii) Calculate the average cost per invitation when 75 invitations are ordered. 1

End of Question 23

Question 24 (13 marks) Use a SEPARATE writing booklet.

(a) Simplify: $\frac{3t^2}{s} \div \frac{5st}{6}$ 2

(b) The ordered back-to-back stem-and-leaf plot below shows the distribution of maximum temperatures in Sydney and Melbourne over the last fortnight of January this year.

Sydney		Melbourne
	1	8 9
9 9 8 8 7 7 6 5 4 3	2	3 6 9
4 2 1	3	1 2 6 6 6
1	4	1 3 4 5

- (i) What was the highest recorded temperature? 1
- (ii) What was Sydney's median temperature in the last fortnight of January? 1
- (iii) Compare and contrast the two data sets by examining the shape and skewness of the distributions, and the measures of location and spread. 3

(c)

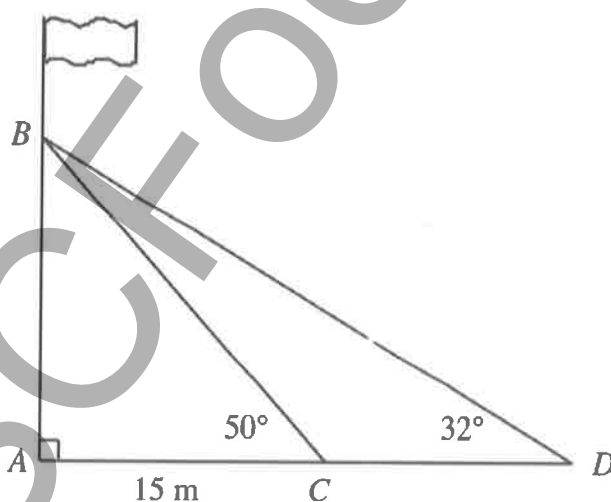

The diagram above shows a flag pole AB with two supporting wires, BC and BD . The supporting wire at C is 15 metres from the base of the flagpole at A , as shown in the diagram above.

- (i) Calculate the length of BC . Give your answer correct to 1 decimal place. 2
- (ii) Find the distance CD , correct to the nearest metre. 2

Question 24 continues on Page 12

Question 24 (continued)

- (d) Liam is a real estate agent. He earns \$400 per week plus commission on any sales that he makes. His commission is calculated using the schedule below.

2

Value of Sale	Commission
Less than \$60 000	5%
\$60 001 – \$120 000	\$3000 plus 2% of each dollar over \$60 000
Over \$120 000	\$4200 plus 1.5% of each dollar over \$120 000

Last week Liam sold a block of land for \$110 000. Calculate Liam's income for that week.

End of Question 24

HSCFOCUS.COM

Question 25 (13 marks) Use a SEPARATE writing booklet.

- (a) Renata has a credit card with an interest rate of 20.44% p.a. There is no interest free period.
- (i) Show that the daily interest rate is 0.056%. 1
 - (ii) Renata purchases a new laptop computer for \$2699 using her credit card. She pays the card off, in full, after 23 days. What amount did she need to pay? 2

- (b) Emma has completed a survey of the hair colour of the students in her Year 10 class. She displayed the data in the following column graph.

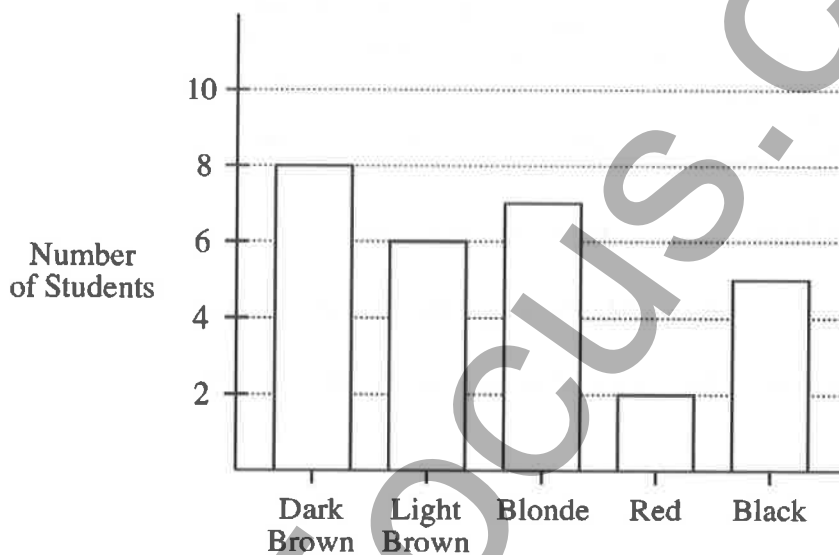

- (i) How many students are there in Emma's Year 10 class? 1
- (ii) One student is chosen at random. What is the probability that the student's hair is light brown or dark brown? 1
- (iii) 1



Copy the probability scale above into your answer book. Indicate on the scale where the probability of a student's hair being black would lie.

Question 25 continues on Page 14

Question 25 (continued)

- (c) Julie is planning to take an overseas trip in 3 years which is expected to cost her \$12 000. She can afford to contribute \$300 at the end of each month into an account that pays interest at 3.6% p.a., compounded monthly.
- (i) Will Julie have enough money to pay for the trip in 3 years from now? Use mathematical calculations to support your answer. 3
- (ii) By how much will Julie exceed or fall short of her target amount? 1
- (d) Mandi compared her examination results in Food Technology and Hospitality.

	Mean	Standard Deviation	Mandi's Mark
Food Technology	80	12	92
Hospitality	68	10.5	89

- (i) Calculate Mandi's z-score for Food Technology. 1
- (ii) Mandi's z-score for Hospitality is 2. What does this mean? 1
- (iii) In which subject did Mandi perform best? Explain your answer. 1

End of Question 25

Question 26 (13 marks) Use a SEPARATE writing booklet.

Marks

- (a) (i) How many different number plates can be formed with three letters followed by three numbers? **1**
- (ii) How many different number plates can be formed with three letters followed by three numbers when any letter or number can only appear once? **1**
- (b) Scott and Kelly are considering a home loan. They can afford repayments of \$275 per week. They take out a loan over a term of 25 years at an interest rate of 5.2% p.a., with interest compounded weekly.
- (i) Show that Scott and Kelly can afford to borrow \$200 005. **2**
- (ii) What would be the benefits of paying an extra \$25 per week on their housing loan? **1**
- (c) A medical study of 780 people of various ages came up with the following results.

	Age 55 or less	Age over 55	Total
People who had a heart attack	A	75	104
People who did not have a heart attack	401	B	676
Total	430	350	780

- (i) Calculate the values of A and B in the table. **2**
- (ii) If one of the people in the study is selected at random, what is the probability that they have not suffered a heart attack? **1**
- (iii) If a person older than 55 is selected at random, what is the probability that they have suffered a heart attack? **1**

Question 26 continues on Page 16

Question 26 (continued)

- (d) A large cylindrical reservoir is used to store water. The reservoir is 36 metres in diameter and has a height of 7 metres.

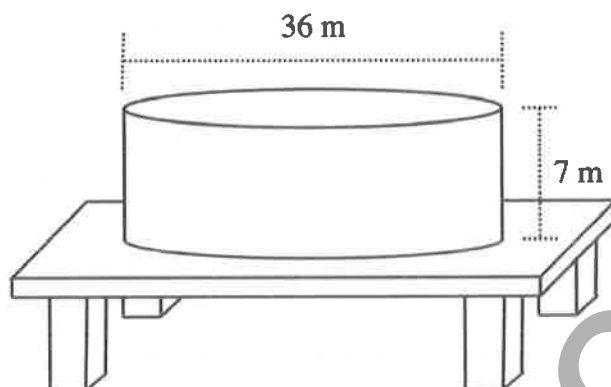

- (i) Calculate the volume of the reservoir to the nearest cubic metre. 2
- (ii) In one day during summer the reservoir dropped by 2545 kL. What drop in water level does this represent? Give your correct to 1 decimal place. 2
[Use $1 \text{ m}^3 = 1 \text{ kL}$.]

End of Question 26

Question 27 (13 marks) Use a SEPARATE writing booklet.

- (a) A refrigerator was bought wholesale from a manufacturer for \$800. This cost price was marked up by 30% to set the retail price. During the half-yearly sale the price on the refrigerator was marked down by 30%. What was the discount price of the refrigerator during the sale? 2

- (b) From his game history, the probability that a footballer kicks a goal is 0.7. In a particular match, the footballer has two shots at goal.

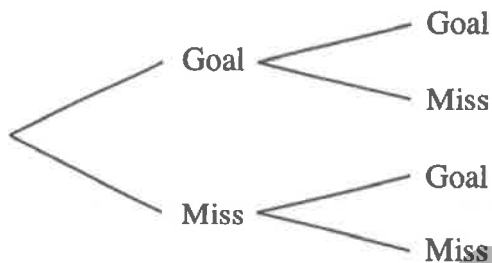

- (i) Copy and complete the probability tree diagram above to represent the possible outcomes. 1
- (ii) What is the probability that he misses both shots? 1
- (iii) What is the probability that he kicks only one goal? 2
- (c) Two boats sailed out of Cairns heading for popular dive sites on the Great Barrier Reef. The first sailed north-east for 55 nautical miles. The second sailed on a bearing of 125° for 47 nautical miles, as shown in the diagram below. 2

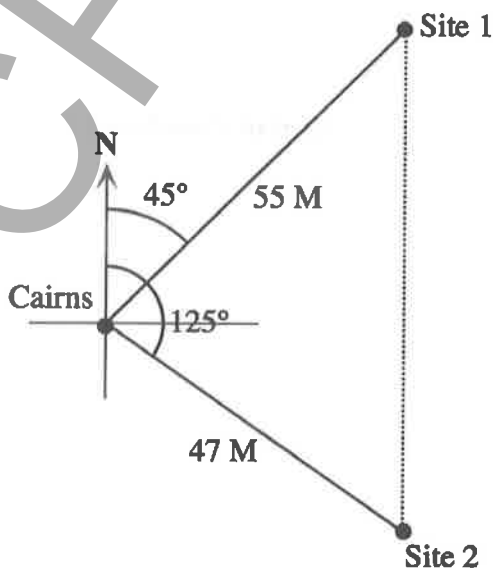

Find the distance between the two dive sites. Give your answer correct to the nearest nautical mile.

Question 27 continues on Page 18

Question 27 (continued)

- (d) For the school fête, two separate spaces need to be fenced off. The school decides to create a square and a rectangle, and has 140 metres of fencing available. For the rectangle, the length must be three times the width.

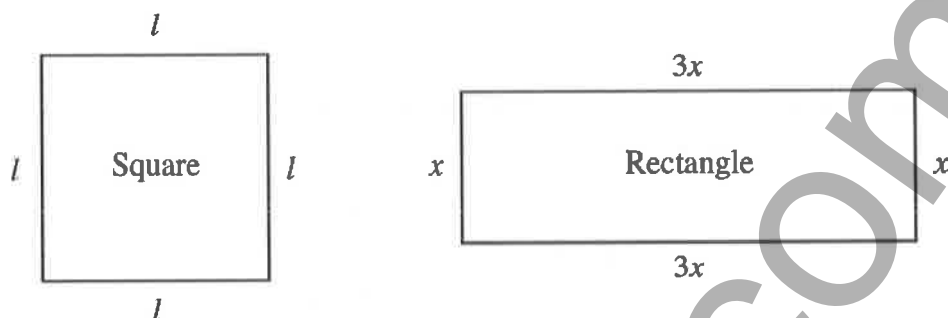

- (i) Find an expression for the length of the square (l) in terms of the width of the rectangle (x). 2

It can be shown that the combined area (A) of the square and the rectangle is given by $A = 1225 - 140x + 7x^2$.

- (ii) Using half a page, draw a neat graph of the combined area (A) of the square and the rectangle against the width of the rectangle (x). 2
Use the horizontal axis for x (from $x = 0$ to $x = 30$) and use the vertical axis for A (from $A = 0$ to $A = 2500$).
- (iii) By referring to your graph, or otherwise, find the minimum possible area of the two spaces. 1

End of Question 27

Question 28 (13 marks) Use a SEPARATE writing booklet.

- (a) Simon bought a trailer for his private lawn-mowing business. After 5 years he sold the trailer for $\frac{1}{4}$ of its original price. Using the declining balance method, calculate the annual rate of depreciation. 3
- (b) The weights and heights of ten Year 12 students were measured and recorded in the table below.

Student	A	B	C	D	E	F	G	H	I	J
Weight (kg)	74	61	57	55	82	63	51	76	70	58
Height (cm)	172	165	174	160	180	164	154	171	155	163

The weights and heights of the students have been plotted in the scatterplot below. The line of best fit is also shown.

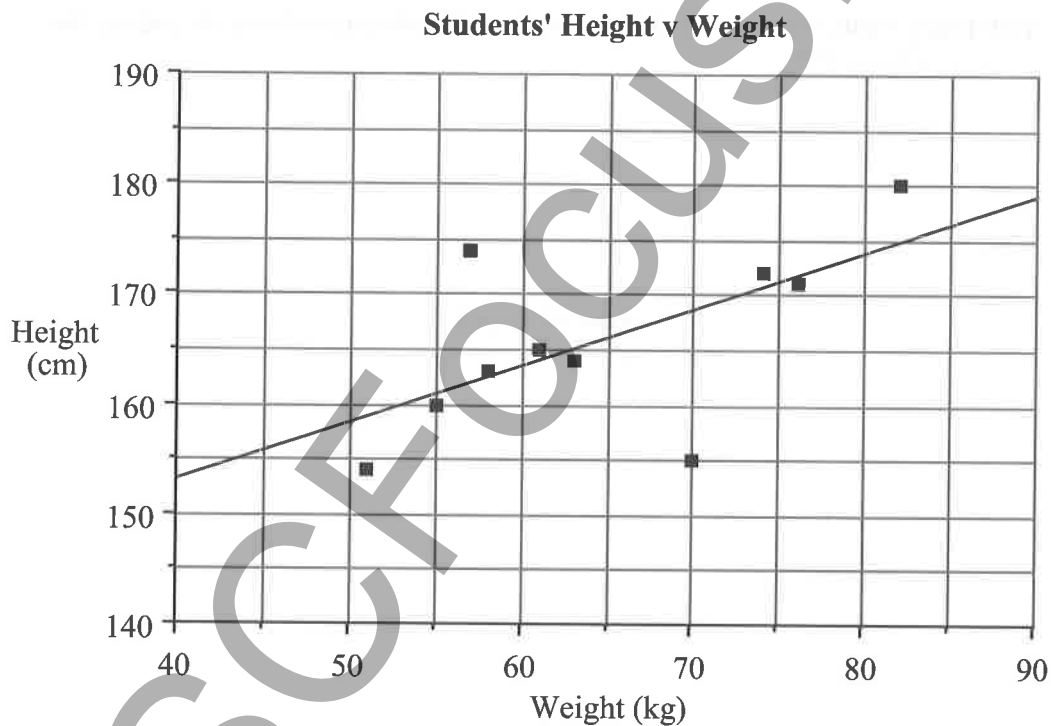

- (i) Another student has a weight of 80 kg. Use the line of best fit in the graph above to predict her height. 1
- (ii) David proposes that the taller you are, the more you will weigh. Do you agree or disagree with his proposal? Use information in the table and graph to support your answer. 2

Question 28 continues on Page 20

Question 28 (continued)

- (c) Paul earned \$315 in simple interest from investing an amount for 18 months at 7.5% p.a. How much did he invest? **2**
- (d) *Dice Chase* is a game played with two dice and two players. Each player takes a die. If a 1 or 6 is thrown then the die must be passed to the other player, who will then win the game. Bill and Julie decide to play a game of *Dice Chase*. Bill goes first.
- (i) Explain why the probability of Bill winning the game on his first turn is $\frac{1}{3}$. **1**
- It can be shown that the probability of the game ending after n turns is given by the formula:
- $$P(\text{game ending after } n \text{ turns}) = 1 - \left(\frac{2}{3}\right)^n$$
- (ii) Find the probability that Julie will win the game on her first turn (the 2nd turn of the game). **1**
- (iii) How many turns must Bill and Julie take so that the probability of ending the game is at least 99%? **3**

End of paper

EXAMINERS

Bill Waddell (Convenor)
 Vicki Attard
 Patrick Curteis
 Neila Darrough
 Julie MacDougal

St Patrick's Marist College, Dundas
 Marian College, Kenthurst
 Kambala, Rose Bay
 Bethany College, Hurstville
 Rosebank College, Five Dock