

# NEWINGTON COLLEGE



--	--	--	--	--

Please write your 4/5 digit STUDENT NUMBER neatly in the boxes.

## Physics

2001

TRIAL HSC EXAMINATION

### Section I

Pages 2-28

Total marks (75)

This section has two parts, Part A and Part B

#### Part A

Total marks (15) Pages 3-10

- Attempt Questions 1-15
- Allow about 30 minutes for this part

#### Part B

Total marks (60) Pages 11-28

- Attempt Questions 16-38
- Allow about 1 hour and 45 minutes for this part

**Section I is presented in THREE sections:**

- ◆ Part A and Part B, Questions 16-22
- ◆ Part B2, Questions 23-30
- ◆ Part B3, Questions 31-37

### Section II

Pages 29-36

Total marks (25)

- Attempt ONE question from Questions 38-40
- Allow about 45 minutes for this section

### General Instructions

- Reading time – 5 minutes
- Working time – 3 hours
- Board-approved calculators may be used
- Write using blue or black pen
- Draw diagrams using pencil
- A Data Sheet and Periodic Table and Formulae Sheets are provided at the back of this paper.

**Section I****Total marks (75)****Part A****Total marks (15)****Attempt Questions 1-15****Allow about 30 minutes for this part**

Use the multiple-choice answer sheet.

Select the alternative A, B, C or D that best answers the question. Fill in the response circle completely.

**Sample:**  $2 + 4 =$  (A) 2 (B) 6 (C) 8 (D) 9  
A  B  C  D

If you think you made a mistake, put a cross through the incorrect answer and fill in the new answer.

A  B  C  D

If you change your mind and have crossed out what you consider to be the correct answer, then indicate the correct answer by writing the word *correct* and drawing an arrow as follows:

A  B  C  D   
*correct* →

- 1 The following diagram represents 2 planets, **A** and **B**, of the same radius and a comparison of the relative strengths of the gravitational fields they create around them.

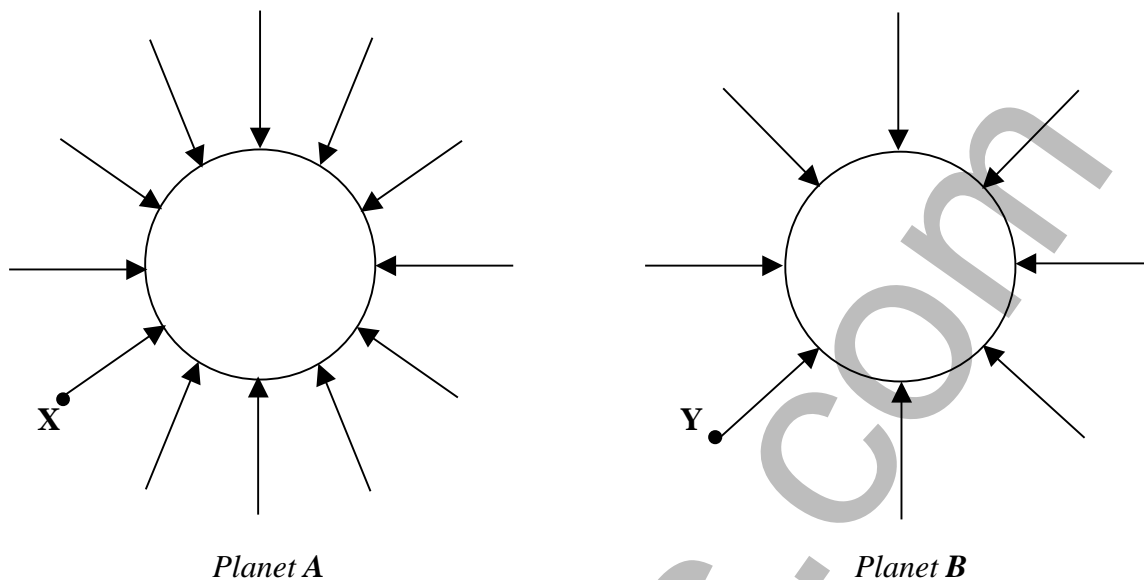

Which of the following statements *best* compares the situations?

- (A) The acceleration due to gravity is identical at the surface of each planet.  
 (B)  $E_p$  of an object, mass  $m$ , at point X is less than  $E_p$  of a object, mass  $m$ , at point Y.  
 (C)  $F_g$  of an object, mass  $m$ , at point X is less than  $F_g$  of a object, mass  $m$ , at point Y.  
 (D) The density of *Planet A* is greater than the density of *Planet B*.
- 2 A projectile follows a parabolic arc from point A to point B to point C, as represented in the following diagram

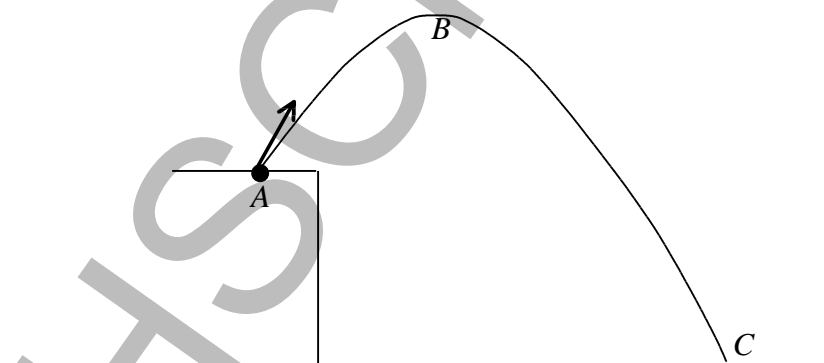

Neglect air resistance. Which of the following statements is correct?

- (A) The total time of flight from A to C is twice the flight time from A to B.  
 (B) The horizontal component of velocity is greatest at point B and least at point C.  
 (C) The vertical acceleration on the projectile depends on the initial launch velocity.  
 (D) The horizontal component of velocity at C depends on the initial launch velocity.

- 3 Suppose that, in the distant future, a *manned* space mission is planned to explore a nearby Sun-like star 50 light years from Earth. The spacecraft accelerates to a speed of  $0.5c$  after travelling a distance of 10 light years, then travels for a distance of 30 light years at this speed and then decelerates for the remaining 10 light years.

The most important problem to be faced during such a mission would be that

- (A) the length contraction at such a high speed could crush the astronauts  
 (B) the  $g$  forces during the acceleration and deceleration phases of the mission would be lethal to astronauts  
 (C) the speeds involved would be such that astronauts would die before reaching the star  
 (D) although no fuel is needed to decelerate the spacecraft, an excessive amount is needed during the first 40 years of travel
- 4 The following diagram represents 3 observers:  $O_1$  on a planet;  $O_2$  in a spacecraft approaching the planet radially at  $0.9c$ ;  $O_3$  in a spacecraft travelling on a path at a tangent to the surface of the planet at  $0.9c$ .

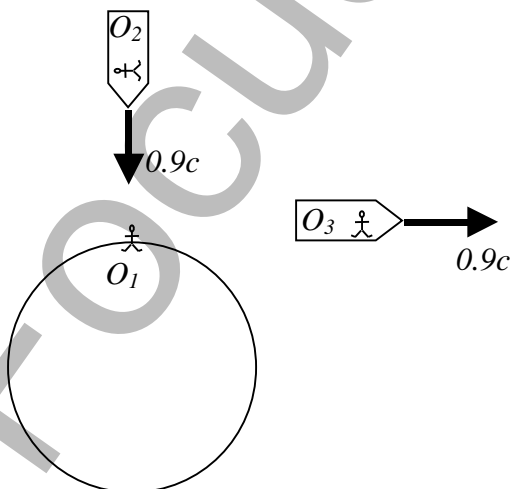

Which of the following statements *best* agrees with Einstein's theory of special relativity?

- (A)  $O_1$  observes less relativistic change of  $O_2$  than of  $O_3$ . This is because  $O_2$  is approaching  $O_1$ , whereas  $O_3$  is moving away.  
 (B)  $O_2$  notices that his body length has contracted because he is moving at the relativistic speed of  $0.9c$ .  
 (C) Each observer observes the other 2. The greatest amount of apparent length contraction occurs for  $O_2$  observing  $O_3$  and for  $O_3$  observing  $O_2$  because they have the greatest relative velocities.  
 (D) Since  $O_1$  is on the planet,  $O_2$  and  $O_3$  do not observe any apparent length contraction of his body.

- 5 The following diagram represents the Michelson-Morley experiment.

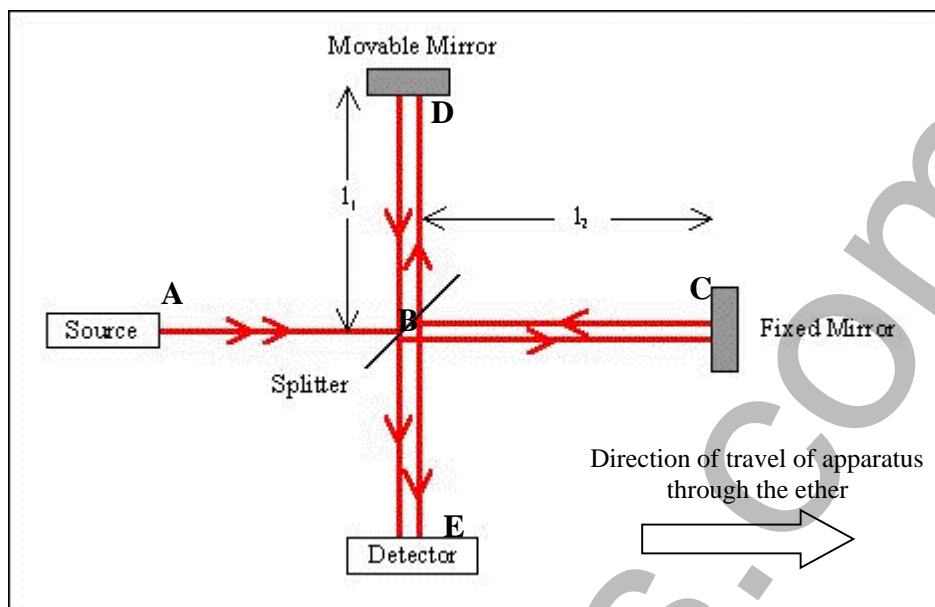

Suppose that the luminous ether really *did* exist and that the apparatus was moving through it to the right, as indicated.

In an experiment, the apparatus was adjusted so that  $l_1 = l_2$ .

Which of the following *best* describes the situation?

- (A) Photons on the path  $A \rightarrow B \rightarrow C \rightarrow B \rightarrow E$  have a *shorter* travel time than photons on the path  $A \rightarrow B \rightarrow D \rightarrow B \rightarrow E$ . There will be an interference pattern.
- (B) Photons on the path  $A \rightarrow B \rightarrow C \rightarrow B \rightarrow E$  have a *longer* travel time than photons on the path  $A \rightarrow B \rightarrow D \rightarrow B \rightarrow E$ . There will be an interference pattern.
- (C) The two rays will interfere destructively at the detector, regardless of the speed of the apparatus through the ether.
- (D) The two rays travel the same distance to the detector. Hence, they arrive at the detector at the same time, regardless of the speed through the ether. There will be no interference pattern.

- 6 An ideal transformer, shown below, has more turns of wire in the secondary coil than in the primary coil.

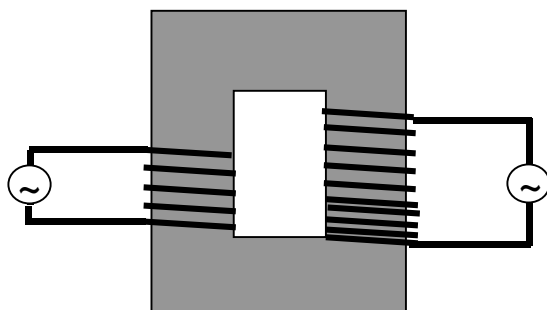

The purpose of this transformer is to

- (A) increase the current in the secondary coil while the voltage remains
  - (B) increase the voltage in the secondary coil while the current remains constant
  - (C) increase both the current and the voltage in the secondary coil
  - (D) increase the voltage and decrease the current in the secondary coil
- 7 The diagram below shows a conductor being moved to the right through a magnetic field.

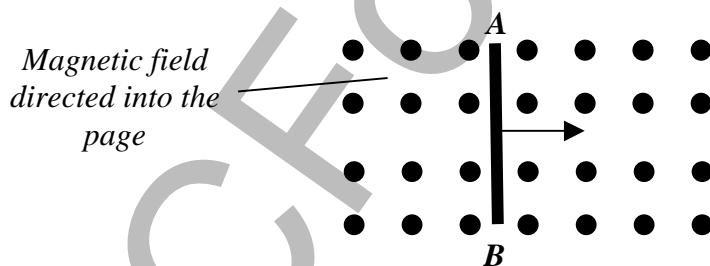

Which of the statements below best describes what will occur in the conductor?

- (A) A potential difference will be induced between the two ends and the electrons will flow towards the end labelled B.
- (B) A potential difference will be induced between the two ends and the electrons will flow towards the end labelled A.
- (C) The conductor will experience a force and move down the page.
- (D) The conductor will experience a force and move up the page.

8 Which of the following diagrams represents an AC motor?

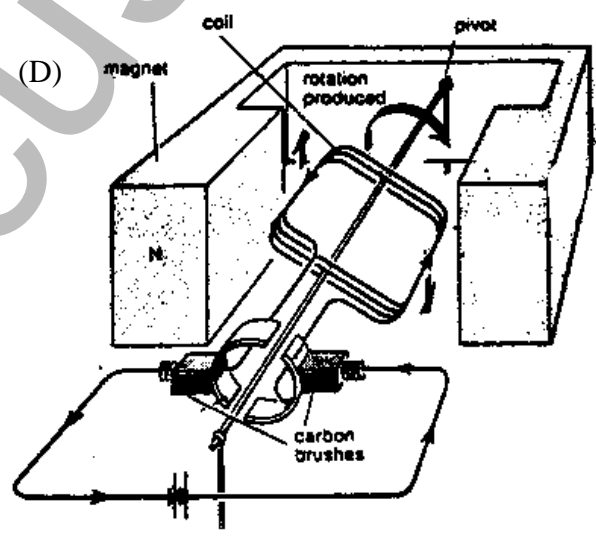
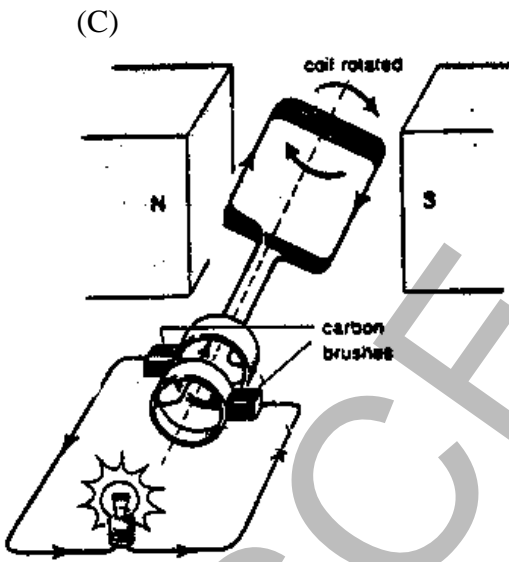
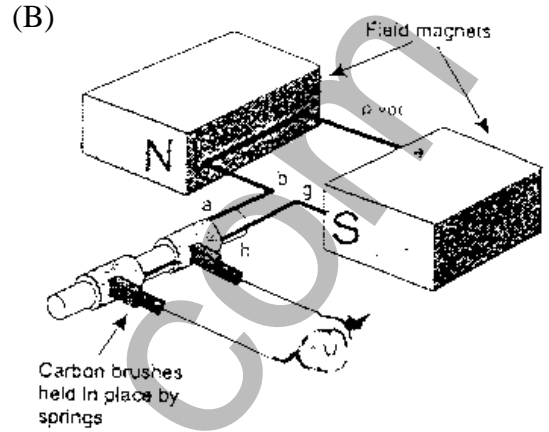
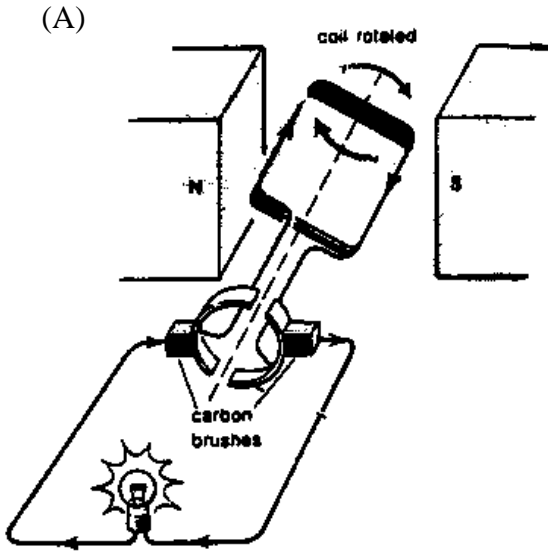

- 9 The graph below shows the change in flux over time for a coil of wire in a generator.

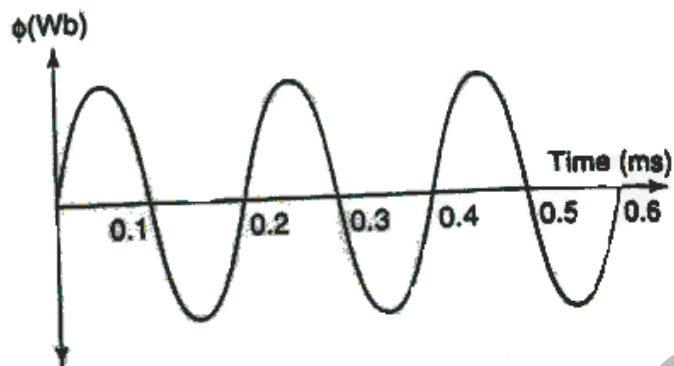

The generator supplies zero voltage

- (A) at no time, since it is constantly producing voltage
  - (B) at all times, since no voltage is being generated
  - (C) at times when the graph line shows a maximum or minimum
  - (D) when the graph line passes through the zero flux axis
- 10 The rectangular loop of wire shown in the diagram below has sides measuring  $40 \text{ mm} \times 40 \text{ mm}$  and is supported on an axle. It carries a current of  $10 \text{ A}$  and is in a uniform magnetic field of strength  $0.01 \text{ T}$ .

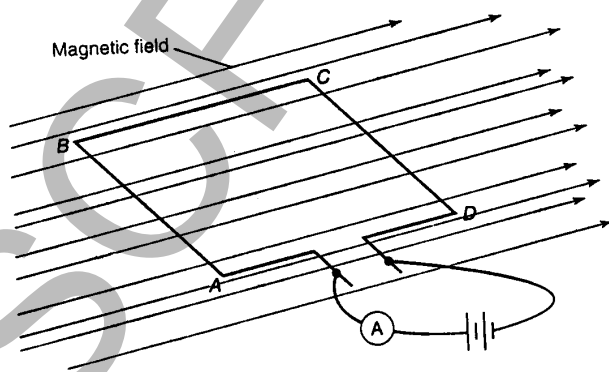

The force on the side CD is:

- (A)  $0.004 \text{ N}$  up
- (B)  $0.004 \text{ N}$  down
- (C)  $0.014 \text{ N}$  up
- (D)  $0.014 \text{ N}$  down



- 11** In which of the following situations would radio waves not be produced?
- (A) a spark plug operating to start a car
  - (B) switching on a fluorescent light
  - (C) a metal post pushed into the ground
  - (D) a lightning bolt
- 12** The components in electrical circuits which were replaced by transistors are
- (A) resistors
  - (B) vacuum tubes
  - (C) semi-conductors
  - (D) superconductors
- 13** A current of 2.0 A flows in a wire. The number of electrons passing a point on the wire each second is
- (A) 2.0
  - (B)  $3.2 \times 10^{-19}$
  - (C)  $6.3 \times 10^{18}$
  - (D)  $1.3 \times 10^{19}$
- 14** In electrical circuits, semiconductors are used in transistors. Transistors act most like
- (A) inductors
  - (B) rheostats with no electrical resistance
  - (C) sensitive ammeters
  - (D) one-way valves for electric current

- 15 The following diagram shows a pair of electrons moving through a lattice of positive ions. One electron attracts positive ions towards it and this region of enhanced positive charge attracts the second electron.

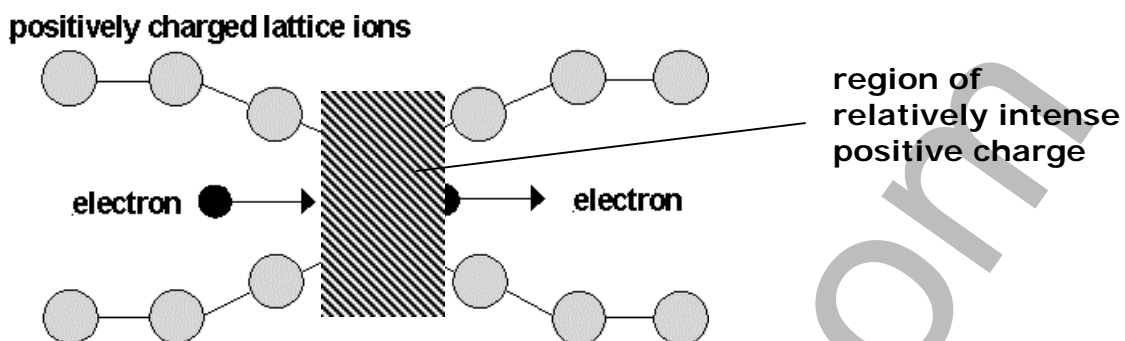

Source: [http://members.ozemail.com.au/~emeryrg/9\\_4\\_from\\_ideas\\_to\\_implementation.htm#BCS](http://members.ozemail.com.au/~emeryrg/9_4_from_ideas_to_implementation.htm#BCS)

The diagram illustrates

- (A) the Meissner effect
- (B) the photoelectric effect
- (C) the Bardeen-Cooper-Schrieffer theory
- (D) semiconductivity

# Section I

## Part B

Total marks (60)

Attempt Questions 16-38

Allow about 1 hour and 45 minutes for this part

Answer the questions in the spaces provided.

Show all relevant working in questions involving calculations.

---

### Question 16 (3 marks)

Marks

During your HSC course, you performed an investigation to gather data and hence determine a value for  $g$ , the acceleration due to gravity.

3

*Outline* the specific technology that you used to gather the data and the nature of the data that you gathered.

*Outline* sources of error using this technology, in order to *explain* why data can vary on each trial of such an experiment and why experimental estimates of  $g$  often vary from  $9.8 \text{ m s}^{-2}$ .

.....

.....

.....

.....

.....

.....

.....

.....

.....

.....

**Question 17** (2 marks)

Rapid modern telecommunications rely on geostationary satellites orbiting at a height of about 36 thousand km. These communications are obviously very reliable, but they are subject to problems.

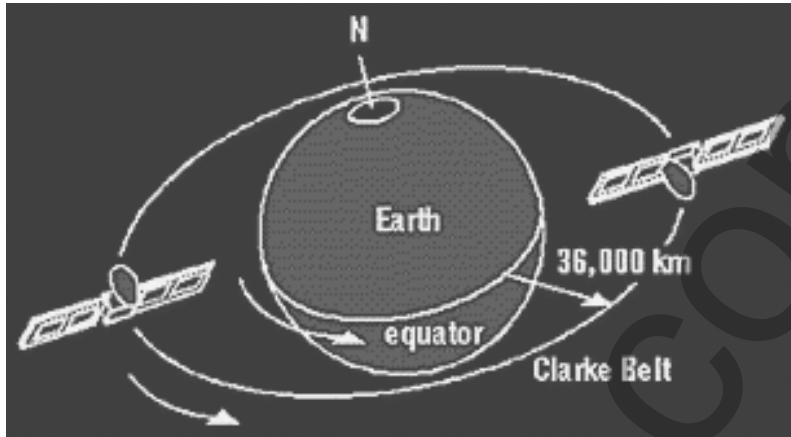

Explain a potential problem caused by EACH of the following factors:

- (a) the distance between ground stations and communications satellites

1

.....  
.....  
.....

- (b) the activity of particles in the van Allen radiation belt

1

.....  
.....

**Question 18** (3 marks)

The diagram below shows the intended path of the Cassini-Huygens space probe to Saturn and its giant moon Titan. Cassini was launched almost 4 years ago and will reach Saturn after a “flight” of almost 7 years. Notice that it has already used 3 gravitational slingshot effects, from Venus and Earth, to increase its speed. These manoeuvres have reduced the energy required in the initial launch of Cassini.

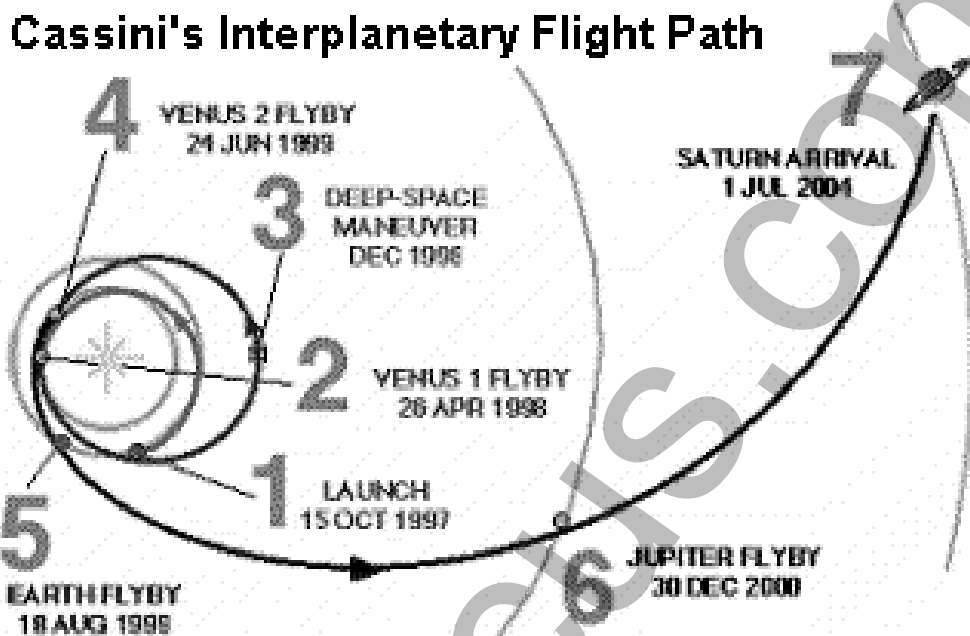

Acknowledgement: [http://www.spacescience.com/headlines/y2000/ast10mar\\_1.htm](http://www.spacescience.com/headlines/y2000/ast10mar_1.htm)

Apply Kepler's 3<sup>rd</sup> Law  $\frac{r^3}{T^2} = G \frac{M_{planet}}{4p^2}$  and conservation of momentum to explain why these gravitational slingshot manoeuvres increase the speed of the probe.

3

.....

.....

.....

.....

.....

.....

.....

.....

.....

.....

**Question 19** (4 marks)

One idea for the future exploration of Mars is to place a communications craft in low Mars orbit (LMO). It would receive data from an array of probes exploring the Martian surface and relay them to Earth.

- (a) Calculate the orbital speed required to maintain a craft in a LMO at a distance of 300 km above the surface of Mars. **2**  
*( $m_{Mars} = 6.6 \times 10^{23} \text{ kg}$ ;  $r_{Mars} = 3.4 \times 10^6 \text{ m}$ )*

.....

.....

.....

.....

.....

- (b) The Martian atmosphere is both less dense and less extensive than Earth's atmosphere. **1**  
*Explain why a LMO satellite is less likely to spiral into Mars than a low Earth orbit (LEO) satellite at a height of 300 km.*

.....

.....

.....

- (c) The spiralling re-entry of a LEO satellite through Earth's atmosphere would destroy it. **1**  
Space Shuttle missions travel in LEO orbits but their re-entry is controlled.  
*Describe how destruction of the Space Shuttle is prevented during its re-entry.*

.....

.....

.....

.....

**Question 20** (4 marks)

Albert Einstein was famous for his *gedanken* – thought experiments which he used to develop and discuss his theories about motion. These thought experiments were necessary because, at the time, technology did not exist to measure experimentally the effects that Einstein proposed.

- (a) *Outline* the details of a typical Einsteinian *gedanken* (thought experiment). **2**

.....

.....

.....

.....

.....

- (b) *Analyse* the predictions the situation makes about the behaviour of objects at relativistic velocities. **2**

.....

.....

.....

.....

.....

.....

HSCFOCUS.COM

**Question 21** (2 marks)

*Summarise* the contribution made by *EITHER*:

Konstantin Tsiolkovsky, Hermann Oberth, Robert Goddard, Robert Esnault-Pelterie, Gerard O'Neill or Werner von Braun

to the development of rocketry and/or space technology.

2

.....

.....

.....

.....

.....

.....

**Question 22** (2 marks)

At present, space travel is very expensive. NASA estimates that:

- the cost of sending 1 kg of cargo into Earth orbit is about \$30 thousand
- the cost of sending one astronaut on a Space Shuttle mission for 2 weeks is about \$200 million
- the cost of an unmanned probe to the surface of Mars is about \$300 million

Use this information to *account for* the high cost of space travel.

2

.....

.....

.....

.....

.....

.....



# PART B2

Please write your 4/5 digit STUDENT NUMBER neatly in the boxes.

--	--	--	--	--

**Marks**

**Question 23** (2 marks)

Upon entering a car at night, a driver turns on his lights and then proceeds to start the ignition with a turn of his key. He notices that the lights in the car and the head lights dim when the car is first starting but they return to their normal brightness very quickly afterwards. *Account* for the dimming of the lights when the car ignition is turned on.

**2**

.....

.....

.....

.....

.....

**Question 24** (2 marks)

Assess the social impact in Australia of the development and use of transformers.

**2**

.....

.....

.....

.....

.....

.....

HSCFOCUS.COM

**PAGE TOTAL**

--

**Question 25** (2 marks)

*Outline* an advantage and a disadvantage of transmitting electricity over large distances using high voltage power lines.

2

.....

.....

.....

.....

.....

**Question 26** (2 marks)

Two metal plates are allowed to swing freely through a magnetic field. The plates are shown below.

2

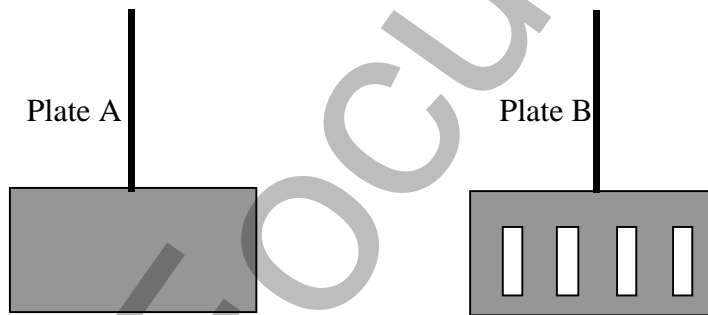

Although both plates are released from the same height, Plate A comes to rest much sooner than Plate B.

*Account for* the difference in swinging time between the plates.

.....

.....

.....

.....

.....

**Question 27** (5 marks)

5

A physics teacher demonstrates Lenz's Law to a class by allowing a steel magnet to fall through a length of aluminium tubing. The time that the magnet takes to fall through the tube is much longer than the time taken by an identical piece of steel that is not magnetic.

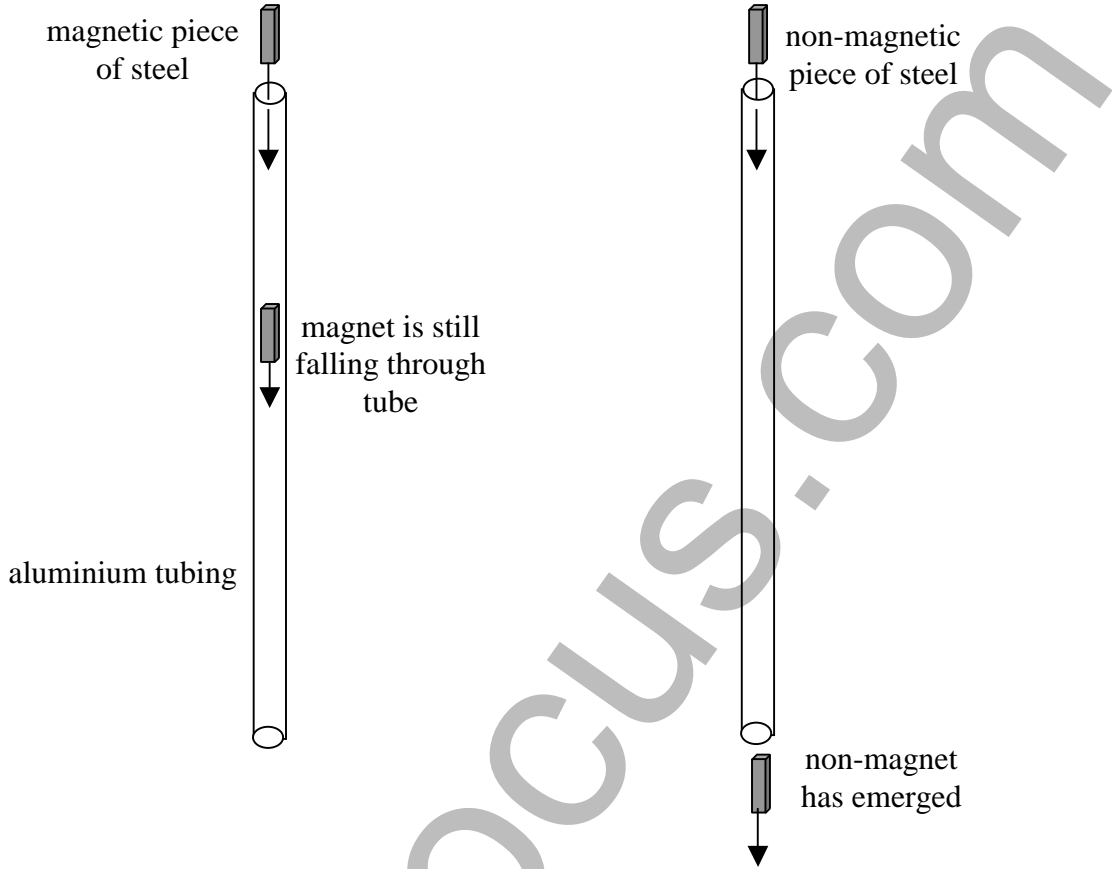

*Explain* how Lenz's Law is applied to this situation and *account* for the observations in terms of the conservation of energy.

.....

.....

.....

.....

.....

.....

.....

.....

.....

.....

**Question 28** (2 marks)

(a) The diagram shows a DC generator.

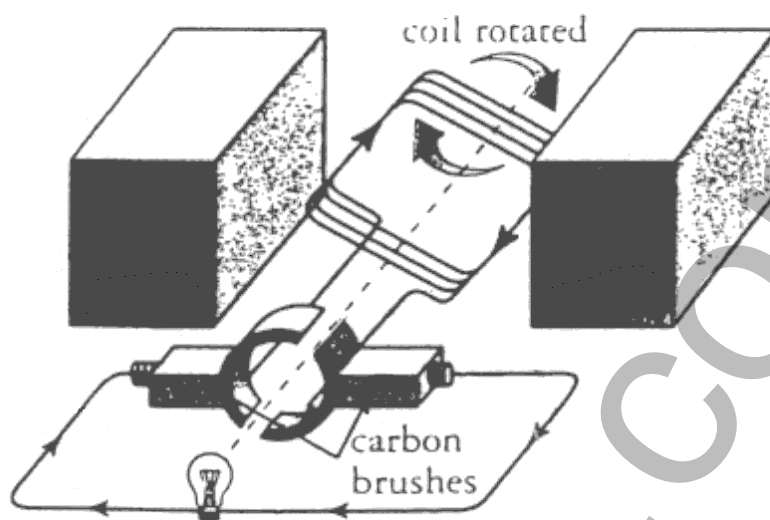

Construct a graph on the axes below to show the resultant EMF when the coil rotates through a full turn.

1



(b) On the same axes above, construct the graph (using a different colour) to show how the EMF might vary if there are 2 coils, identical to the one shown above, arranged at  $90^\circ$  to each other.

1

**Question 29** (2 marks)

*Compare* the function of a split-ring commutator with that of slip rings in motors and generators.

2

.....

.....

.....

.....

.....

**Question 30** (3 marks)

*Outline* the principles behind the operation an AC induction motor. In your answer, clearly *describe* the functions of the stator and the rotor.

3

.....

.....

.....

.....

.....

.....

HSCFOCUS.COM

# PART B3

Please write your 4/5 digit STUDENT NUMBER neatly in the boxes.

--	--	--	--	--

## Question 31 (2 marks)

Marks

Some colours of light falling onto a clean, freshly cut metal surface will produce the photoelectric effect. This effect is used in breathalysers, solar cells and photocells.

(a) *Explain* how a photoelectric current is produced in some cases.

1

.....

.....

.....

(b) *Explain* the principle underlying the use of the photoelectric effect to measure concentrations of alcohol in exhaled air in modern breathalysers.

1

.....

.....

.....

.....

## Question 32 (5 marks)

*Compare* the nature of electrical conductivity in metals with that in doped semiconductors. In your answer, refer to the relationship between the conduction and valence bands in the two types of materials.

5

.....

.....

.....

.....

.....

.....

.....

.....

.....

.....

.....

PAGE TOTAL

--

**Question 33** (3 marks)

Consider the following information about the electromagnetic spectrum.

Wavelength of radiation (m)	Characteristics
$1.0 \times 10^{-12}$	highly penetrating and lethal to humans; in gamma ray band
$5.0 \times 10^{-9}$	can be used to sterilise equipment; can cause skin cancer; in UV band
$1.0 \times 10^{-4}$	commonly emitted by warm objects; not harmful to humans; in IR band
1.0	used for TV transmission; low energy; no established harmful side-effects; in radio band

- (a) *Analyse* this information in terms of the photoelectric effect and quantisation. **2**

.....

.....

.....

.....

.....

.....

.....

- (b) *Calculate* the photon energy of yellow light of wavelength 506 nm. **1**

.....

.....

.....

HSCFOCUS.COM

**Question 34** (3 marks)

(a) *Describe* the method used by the Braggs to determine crystal structures. **2**

.....  
.....  
.....  
.....

(b) *Identify* one feature of crystal structures that this technique reveals. **1**

.....  
.....

**Question 35** (2 marks)

*Explain* why electric currents cause heat to be generated in conducting metallic wires. **2**

.....  
.....  
.....  
.....

**Question 36** (2 marks)

Louis de Broglie attributed standing wave characteristics to electrons in order to justify why their energies appeared to be quantised. **2**

*Describe* the relationship between the circumference of an electron orbit and the wavelength associated with this orbit, according to de Broglie's theory.

.....  
.....  
.....  
.....  
.....



**Question 37** (3 marks)

*Discuss* potential advantages of using superconductors and *identify* current limitations to their use.

**3**

.....

.....

.....

.....

.....

.....

.....

HSCFOCUS.COM