

St George Girls High School

Trial Higher School Certificate Examination

2010



Mathematics

Extension 1

General Instructions

- Reading time – 5 minutes
- Working time – 2 hours
- Write using blue or black pen
- Begin each question on a new booklet
- Write your student number on each page
- All necessary working must be shown.
- Diagrams are not to scale.
- Board-approved calculators may be used.
- The mark allocated for each question is listed at the side of the question.
- Standard Integrals sheet may be detached.

Total Marks – 84

- Attempt ALL questions.
- All questions are of equal value.

Students are advised that this is a Trial Examination only and does not necessarily reflect the content or format of the Higher School Certificate Examination.

Question 1 – (12 marks) – Start a New Booklet

Marks

a) Evaluate

2

$$\lim_{x \rightarrow 0} \frac{5x}{\sin 2x}$$

b) Find

2

$$\int \frac{dx}{16 + x^2}$$

c) Evaluate

3

$$\int_{\frac{\pi}{9}}^{\frac{\pi}{6}} \sin 3x \cos 3x \, dx$$

d) Sketch the graph of $y = \cos(\cos^{-1} x)$, showing all important features.

2

e) Find

3

$$\int x^2 e^{x^3-1} \, dx$$

using the substitution $u = x^3 - 1$

Question 2 – (12 marks) – Start a New Booklet

Marks

- a) Point $P(19, 10)$ divides the interval AB externally in the ratio 2:3. Point A has coordinates $(3, y_1)$, and B has coordinates $(x_2, 1)$.

Find the values of y_1 and x_2 .

3

- b) Solve $5 \sin x - 7 \cos x = 3$ for $0^\circ \leq x^\circ \leq 360^\circ$, by using the substitution $t = \tan \frac{x}{2}$

4

- c) Find the acute angle between the lines $2x - 3y + 8 = 0$ and $5x - 2y - 9 = 0$

2

- d) Find the equation of the tangent to the curve $y = \cos^{-1} 2x$ at the point where $x = 0$

3

Question 3 – (12 marks) – Start a New Booklet

Marks

- a) The acceleration of a particle is given by $\ddot{x} = -4x$
- (i) Show that $x = 3 \sin 2t$ is a solution to this differential equation. 1
 - (ii) Find the times when the particle returns to the origin during the first 4 seconds of the motion. 1
 - (iii) Find the velocity of the particle at these times. 1
 - (iv) Find the equation of its velocity in terms of its displacement. 2

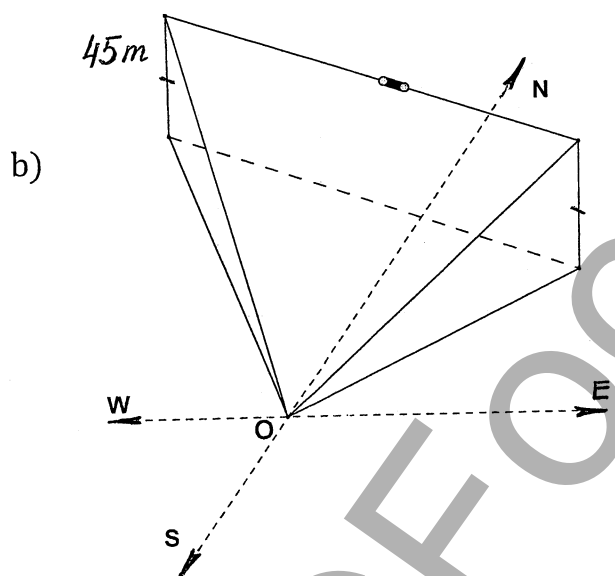

A cable car is travelling at a constant height of 45 m above the ground. An observer on the ground at point O sees the cable car on a bearing of $335^\circ T$ from O with an angle of elevation of 28° .

After 1 minute the cable car has a bearing of $025^\circ T$ from O and a new angle of elevation is 53° .

Find:

- (i) the distance the cable car has travelled in that minute. 3
 - (ii) its speed in metres per second. 1
- c)
- (i) Express $\sqrt{3} \sin 2x + \cos 2x$ in the form $R \sin(2x + \alpha)$, where α is an acute angle in radians. 2
 - (ii) Hence or otherwise find the general solution to the equation 1

$$\sqrt{3} \sin 2x + \cos 2x = 0$$

Question 4 – (12 marks) – Start a New Booklet

Marks

- a) Julie decided to contribute \$200 at the beginning of each month to her savings account, which pays interest at the rate of 9% per annum compounded monthly.

- (i) Show that the expression for A_n , the value of Julie's savings at the end of n^{th} month is given by the formula

2

$$A_n = 200 \frac{1.0075(1.0075^n - 1)}{1.0075 - 1}$$

- (ii) How much time would it take for her savings to grow above \$90 000?

2

- b) The polynomial $P(x)$ is given by

$$P(x) = x^3 + (2 - k)x^2 + (4 - 2k)x + 8$$

- (i) Show that $x = -2$ is a root of $P(x) = 0$

1

- (ii) Given that $P(x) = (x + 2)(x^2 - kx + 4)$, find the set of values of k such that $P(x) = 0$ has 3 distinct real roots.

3

- c) For positive integers n and r , where $r < n$, show that

2

$${}^nC_r + {}^nC_{r+1} = {}^{n+1}C_{r+1}$$

- d) Given that the roots of $2x^3 - 6x^2 + x + 3 = 0$ are α, β and γ , show that

2

$$2(\alpha\beta + \alpha\gamma) = 1 - 2\beta\gamma$$

Question 5 - (12 marks) - Start a New Booklet

Marks

- a) Prove, using the Principle of Mathematical Induction that $5^n - 1$ is divisible by 4 for all integer $n \geq 1$ 3
- b) The polynomial $P(x) = 5x^3 + 3x^2 + 1$ has one real root in the interval $-1 < x < 0$
- (i) Sketch the graph of $y = P(x)$ for $-1 \leq x \leq 1$. Clearly label any stationary points. 2
- (ii) Let $x = -\frac{1}{5}$ be the first approximation to the root. Apply Newton's method once to obtain another approximation to the root. 2
- (iii) Explain why the application of Newton's method in part (ii) was not effective in improving the approximation to the root. 1
- c) (i) Show that in the binomial expansion of $\left(x - \frac{1}{x}\right)^{2n}$, the term independent of x is $(-1)^n {}^{2n}C_n$ 1
- (ii) Show that $(1+x)^{2n} \left(1 - \frac{1}{x}\right)^{2n} \equiv \left(x - \frac{1}{x}\right)^{2n}$ 1
- (iii) Deduce that $({}^{2n}C_0)^2 - ({}^{2n}C_1)^2 + ({}^{2n}C_2)^2 - \dots + ({}^{2n}C_{2n})^2 = (-1)^n {}^{2n}C_n$ 2

Question 6 – (12 marks) – Start a New Booklet

Marks

A ball is thrown from a height h metres with initial speed V metres per second at an angle θ with the horizontal. The top of a net N , also of height h metres is S metres from the point where the ball was thrown.

- (i) The equations of motion of the ball are

4

$$\ddot{x} = 0 \text{ and } \ddot{y} = -g$$

Using calculus, show that the position of the ball at time t is given by

$$\begin{aligned}x &= Vt \cos \theta \\y &= Vt \sin \theta - \frac{1}{2}gt^2 + h\end{aligned}$$

- (ii) Hence show that the trajectory equation of the ball is

2

$$y = h + x \tan \theta - \frac{gx^2}{2V^2 \cos^2 \theta}$$

- (iii) The ball clears the net. Show that

2

$$V^2 \geq \frac{Sg}{\sin 2\theta}$$

- (iv) After clearing the net, the ball hits the ground at point Q , which is d metres on the other side of the net. Show that

4

$$\frac{Sh}{(S+d)d} \leq \tan \theta$$

Question 7 – (12 marks) – Start a New Booklet

Marks

a) $P(2ap, ap^2)$ is a point on the parabola $x^2 = 8y$. The normal at P cuts the y -axis at Q . M is the midpoint of QP .

(i) Show that the normal at P has equation $x + py = 4p + 2p^3$ 2

(ii) Show that M has coordinates $(2p, 2p^2 + 2)$ 2

(iii) Show that the locus of M is a parabola with vertex $(0, 2)$ 1

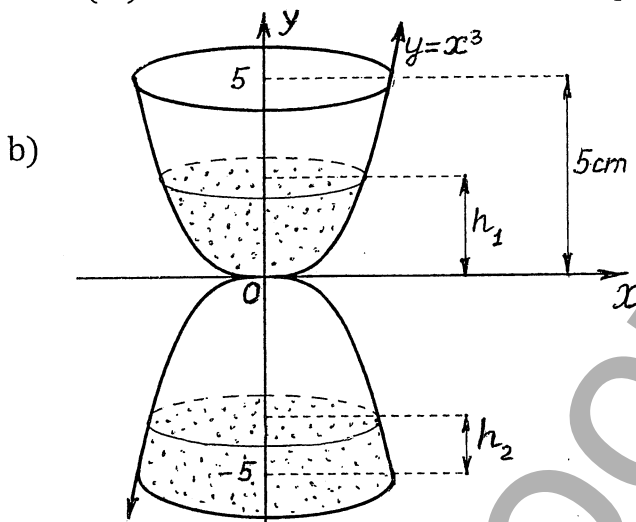

An hourglass timer is formed by revolving the curve $y = x^3$ from $y = -5$ cm to $y = 5$ cm around y -axis.

(i) If the top half of the hourglass is filled with sand show that the volume of sand is 27.56 cm^3 . (correct to 2 decimal places). 2

(ii) If a quarter of the sand is in the bottom half of the hourglass and the rest is in the top half, find the heights of the levels of sand in the top (h_1) and the bottom (h_2) halves to the nearest mm. 3

(iii) There is a small hole between the two halves of the hourglass (at $(0, 0)$) through which the sand flows from top to bottom at a constant rate of $b \text{ cm}^3/\text{s}$.

Show that the rate at which the sand level in the top half of the hourglass, h_1 , is changing is

$$-\frac{b}{\pi h_1^{\frac{2}{3}}}$$

2